



Department of Energy

Richland Operations Office
P.O. Box 550
Richland, Washington 99352

SEP 29 1995

95-TSD-122

The Honorable John T. Conway
Chairman
Defense Nuclear Facilities Safety Board
Suite 700
625 Indiana Avenue, NW
Washington, D.C. 20004

Dear Mr. Conway:

TRANSMITTAL DOCUMENTATION FOR CLOSURE OF DEFENSE NUCLEAR FACILITY SAFETY BOARD (DNFSB) 93-5 COMMITMENTS 1.20, JAN95 B01, AND JAN95 B04

This letter is to advise the DNFSB that the U. S. Department of Energy, Richland Operations Office (RL), Tank Waste Remediation System (TWRS) has accepted for use in TWRS's activities the enclosed document entitled Risk Acceptance Criteria. With transmittal of this approved document TWRS has completed all technical requirements for the following three related 93.5 DNFSB Commitments:

- 1) 93-5 1.20 "TWRS Risk Acceptance Criteria";
- 2) 93-5 B01 "Plan to Develop Risk Acceptance Guidance"; and
- 3) 93-5 B04 "Develop Safety Risk Acceptance Guidelines".

Please credit us with closure of these important commitments. If you have any questions, please contact Mr. Dennis H. Irby of my staff on (509) 376-5652.

Sincerely,

A handwritten signature in cursive script that reads "Mary F. Jarvis".

Mary F. Jarvis, Ph.D., Project Director
Tank Safety Analysis Division

TSD:MFJ

Attachment

cc w/o attach:

T. P. Grumbly, EM-1, HQ
M. A. Hunemuller, EM-38, HQ
S. P. Cowan, EM-30, HQ
J. V. Antizzo, EM-37, HQ

cc w/attach:

C. S. O'Dell, EM-37, HQ

TWRS RISK ACCEPTANCE CRITERIA

May 1995

Prepared for
Westinghouse Hanford Company
Richland, WA 99352

by
ARES Corporation
San Francisco, CA 94104

L. E. Shipley
L. D. Muhlestein
T. J. Turkow

EXECUTIVE SUMMARY

Applicable Risk Acceptance Criteria have been identified and developed, and are recommended to be used as part of the TWRS waste characterization Data Quality Objectives (DQO) process. The proposed Risk Acceptance Criteria were developed in response to Implementation Plan Commitment 1.20, TWRS Risk Acceptance Criteria, of the Defense Nuclear Facilities Safety Board (DNFSB) Recommendation 93-5. The Risk Acceptance Criteria are intended to provide the basis for development of a relationship between acceptable risk and the required precision and accuracy of Hanford waste characterization data.

The recommended risk acceptance criteria for radiological and toxicological hazards for both the public and workers are based on existing Westinghouse Hanford Company documentation. These criteria have been reviewed and used over the past several years and are being used by several Department of Energy Management and Operating Contractors. The recommended risk acceptance criteria for environmental risk and programmatic risk were developed by this effort.

The recommended environmental risk acceptance criterion has been developed by relating the environmental impact to the cost of cleaning up environmental contamination. The criterion is expressed in terms of the probability of exceeding specific cleanup costs. The potential costs of cleanup were developed by considering information available relative to the cost of cleaning up Environmental Protection Agency Superfund sites. The criterion was compared to the probability of property loss from industrial fires and North Atlantic tropical storms and hurricanes.

The programmatic risk acceptance criterion is expressed in terms of the cost impact from an unwanted programmatic event. The criterion is intended to represent a bounding cost impact and is expressed in terms of the probability of exceeding a specified cost. The criterion was developed by considering programmatic risks in terms of the likelihood of success. The criterion was also compared to other property loss data.

CONTENTS

1.0	INTRODUCTION	1
2.0	OBJECTIVES	2
3.0	CONCEPT OF RISK	2
4.0	RISK ACCEPTANCE CRITERIA	3
4.1	HEALTH AND SAFETY RISK TO PUBLIC AND WORKERS	3
4.2	ENVIRONMENTAL RISK	7
4.3	PROGRAMMATIC RISK	9
4.4	USE OF RISK ACCEPTANCE CRITERIA	11
5.0	CONCLUSION	14
6.0	REFERENCES	14

APPENDIX

A	DISCUSSION OF RISK PERSPECTIVES AND DEVELOPMENT OF RISK ACCEPTANCE CRITERIA
---	--------------------------------------------------------------------------------

LIST OF FIGURES

1	Off-Site Radiological Risk Acceptance Criterion	5
2	Nonradiological Risk Acceptance Criterion	6
3	On-Site Radiological Risk Acceptance Criterion	7
4	Environmental Risk Acceptance Criterion	9
5	Programmatic Risk Acceptance Criterion	11
6.	Illustrative Example of Using Risk Acceptance Criteria	13
7.	Example of a Cost-Reduced Risk Evaluation	13
A-1	Example of a Cumulative Distribution Function (CDF) and a Complementary Cumulative Distribution Function (CCDF)	A-2
A-2	Proposed Environmental Contamination CCDF Compared to the CCDF Developed from Superfund Cleanup Costs and the Average Superfund Cleanup Cost	A-5
A-3	Proposed Environmental Contamination CCDF and Exceedance Frequency Curve	A-6
A-4	CCDF Curves for Industrial Fires, Tropical Storms, Superfund Cleanup Costs, Average Superfund Cleanup Cost and Environmental Contamination	A-7
A-5	An Example of a Cost Cumulative Distribution Function Illustrating the 70% to 80% Programmatic Goal	A-9
A-6	Cost Cumulative Distribution Function (CDF) Scaled to a 70% to 80% Confidence Level of \$100 Million Dollars	A-9
A-7	Complementary Cumulative Distribution Function for Programmatic Costs	A-10
A-8	Comparison of Complementary Cumulative Distribution Functions	A-11

LIST OF TERMS

TWRS	Hanford Tank Waste Remediation Systems
DNFSB	Defense Nuclear Facilities Safety Board
DOE	Department of Energy
EFCOG	Energy Facility Contractors Group, Safety Analysis Working Group
ERPG	Emergency Response Planning Guideline (estimates of concentration ranges for specific chemicals above which acute exposure would be expected to lead to adverse health effects of increasing severity for ERPG-1, -2, and -3)
ICR	Incremental Cancer Risk
PEL-TWA	Permissible Exposure Limit Time-Weighted Average
EPA	Environmental Protection Agency
CCDF	Complementary Cumulative Distribution Function
CDF	Cumulative Distribution Function

1.0 INTRODUCTION

A major effort of the Hanford Tank Waste Remediation System (TWRS) program is the timely characterization of waste within the Hanford waste tanks. On July 19, 1993, the Defense Nuclear Facilities Safety Board (DNFSB) provided to the Secretary of Energy its Recommendation 93-5 (DNFSB 1993), which commented on the Hanford Tank Waste Characterization effort.

In response to the DNFSB's recommendation, the Department of Energy (DOE) and its prime contractor, Westinghouse Hanford Company, prepared an Implementation Plan (DOE-RL 1994a) that identified an improved waste characterization approach. The approach focused, in part, on obtaining historical information on each high-level waste tank, evaluating the sampling needs of each tank for a short list of key safety-related analytes, utilizing sampling data to enhance and expand statistical models, and revising the sampling needs and capabilities based on completed safety screening, safety resolution and risk acceptance criteria.

The Implementation Plan was arranged into seven task initiatives. Associated with each task initiative were specific elements and corresponding commitments. One particular area of the first initiative centered on providing a sound technical basis for waste sampling and analyses. The focus was how much sampling data are actually needed, how accurate must the data be, and how many samples must be collected to establish an acceptable level of risk.

This report addresses one of these commitments, Commitment 1.20 of the Implementation Plan. This commitment states:

Commitment 1.20, TWRS Risk Acceptance Criteria

This will provide an analysis of variables that must be considered and how they affect the outcome of the decisions (e.g., does it affect risk of employee exposure or is it a cost/schedule issue, and how sensitive is the resultant decision to the data). DOE will determine its level of acceptable risk within two months of acceptance of the WHC generated document."

The Implementation Plan noted that without a sound technical basis one cannot determine the sampling accuracy requirements of the TWRS program objectives. Thus, in order to establish the technical basis, it is important to determine the following information: (1) the risk that is acceptable if less than complete information is known about the tank contents; and (2) the definition of the accuracy, precision, detection limit, and action limit for each analyte that has been identified as being important relative to making decisions.

The types of risk may vary with each program element or performance measure. For example, the risk to the waste disposal or pretreatment programs may be cost and schedule impacts if the data gathered by the characterization program are inadequate. On the other hand, not having sufficient characterization information may mean one does not have a sufficient understanding regarding potential risks to the public or workers.

The TWRS Characterization Program is helping programs to identify critical data requirements by using the Environmental Protection Agency's Data Quality Objectives (DQO) process. These data requirements include required analyses, their precision and accuracy, detection levels of interest, action levels of interest and acceptable risk. Data collected from the waste tanks will form a database that will be used in preparing further DQOs. An important element of the TWRS characterization process is to establish the level of risk that the data users, or programs, are willing to accept. If the acceptable risk is large, then the need for precise data may decrease. If the acceptable risk is narrowly defined, then there may be a greater need for more precise data. Thus, there is a direct correlation between acceptable risk and the precision or uncertainty that is required in the characterization data. This relationship between acceptable risk and the accuracy, uncertainty or detection levels of required characterization data is to be developed by the application of Risk Acceptance Criteria within the DQO process.

2.0 OBJECTIVES

The objective of this effort is to identify, develop, and document applicable Risk Acceptance Criteria to be used in the TWRS waste characterization DQO process. Following the development of the Risk Acceptance Criteria, the methodology will be developed to relate the Risk Acceptance Criteria to the TWRS waste characterization process. This methodology will provide the relationship between acceptable risk, as described by the Risk Acceptance Criteria, and the precision, uncertainty, detection levels or action levels of required data.

3.0 CONCEPT OF RISK

Risk is a quantitative or qualitative expression of possible loss which considers both the probability that a hazard will cause harm to a receptor and the consequences of that event. In practice, risk is usually defined in terms of the frequency or likelihood of an undesirable event (events per year) rather than probability (unitless ranging from zero to one).

Risk is often discussed in terms of the health and safety of the public, workers, and environment in the event of an accident. However, in a broader context one can define other undesirable events, such as missing an important milestone, over-running a project cost, or violating a law. The consequences and likelihood (or frequency) of this type of undesirable event can be evaluated and included in what is commonly termed "programmatic risk."

There are several elements of risk that can be considered. Some of the more common ones are outlined as follows:

- Health and Safety Risk to the public and workers;
- Environmental Risk; and
- Programmatic Risk, including cost risk, schedule risk, risks associated with technical requirements, regulatory compliance risk, and political risk.

This discussion will address the health and safety risk to both the public and workers. Environmental risk will be addressed in terms of the cost of cleaning up environmental contamination from an unintentional release. Programmatic risk will be addressed in terms of cost and schedule impacts. Regulatory compliance risk, technical requirements risk and political risk are considered only to the extent that they may affect cost and schedule.

The likelihood (or frequency) of an undesirable event occurring is never zero, but may be small (i.e., on the order of 1 chance of occurring in 10,000 years, or 1×10^{-4} /year). Thus, the corresponding risk of an undesirable event may also be small, but not zero. The question often arises, "How much risk am I willing to accept?" The answer to this question is usually specified in a risk criterion or threshold above which the risk is not acceptable, and something must be done to either decrease the consequences from the event and/or decrease the likelihood that the event might occur. The specific actions to reduce the risk are considered in a cost-benefit analysis, in which the benefit is reduced risk and the most cost effective manner to achieve the risk reduction is determined.

In theory, risk acceptance criteria could be applied to all of the values and objectives of the TWRS program. In practice, those specifically addressed here provide a practical set of criteria that represent the major values that have been voiced by stakeholders (Armacost et al, 1994). Specifically, the health and safety risk criterion addresses the stakeholder value of protecting the public and workers. The environmental risk criterion addresses the stakeholder concern for the environment, and the programmatic risk addresses the effectiveness of the program in achieving stakeholder goals.

4.0 RISK ACCEPTANCE CRITERIA

Risk acceptance criteria specify the range of adverse consequences involved with an endeavor, together with the range of frequencies for which the consequences are considered acceptable. Risk acceptance criteria are intended to provide a measure of the risk that is acceptable, or conversely, a measure of risk that is not acceptable and for which some preventive and/or mitigative action must be taken.

General risk acceptance criteria will be qualitatively discussed for each of the risk elements identified above. How the risk acceptance criteria are to be used and the relationship of risk acceptance criteria to cost-benefit analysis will also be briefly described. A more detailed presentation of the application methodology will be provided in a subsequent document.

4.1 HEALTH AND SAFETY RISK TO PUBLIC AND WORKERS

The DOE Nuclear Safety Policy (DOE 1991) established a public safety goal relative to the operation of DOE facilities. The nuclear safety policy specified prompt and latent fatality safety goals for members of the public near a DOE facility. Hey et al. (Hey 1992) discussed the application of the DOE Nuclear Safety Policy relative to the assessment and management of risk due to accidental radiological releases from Hanford facilities. The document identified a guideline in terms of frequency and consequence that was demonstrated to be a sufficient condition for meeting the DOE Nuclear Safety Goal. That is, if all frequency-consequence pairs associated with identified accident conditions are below the guideline, then the total risk will be less than the safety goal.

The quantitative radiological risk acceptance guideline for the public was defined in terms of the radiological dose consequences to a maximally exposed individual at the site boundary in the direction of the worst-case meteorology. This hypothetical person located at the site boundary in the direction of the contamination plume is defined to be the off-site individual. This radiological risk acceptance guideline for the public is documented in the Westinghouse Hanford Company Nonreactor Nuclear Facility Safety Analysis Manual (WHC 1993). The guideline has been thoroughly reviewed over the past several years by many individuals, including the Department of Energy, and is being used by several Department of Energy Management and Operating Contractors. The risk acceptance guideline from the Nonreactor Nuclear Facility Safety Analysis Manual, shown in Figure 1, is proposed as the public nuclear health and safety risk criterion.

Craig et al. (Craig 1993) developed a risk acceptance guideline for the release of toxic hazardous materials. This toxicological risk acceptance guideline is also part of the Westinghouse Hanford Company Nonreactor Nuclear Facility Safety Analysis Manual. This toxicological risk acceptance guideline, shown in Figure 2, is proposed as the toxicological risk acceptance criterion. The risk acceptance guideline in Figure 2 was first developed for the Westinghouse Management and Operating Contractors by a subcommittee of the Westinghouse Nuclear Facility Committee. Its development was further considered and endorsed by a wider range of Department of Energy contractors associated with the Energy Facility Contractors Group (EFCOG) Safety Analysis Working Group. Review and consideration of the above guidelines includes many organizations including the DOE-EH. The guidelines provide the best consideration of carcinogenic and toxic hazardous materials relative to both the public and workers from a risk perspective.

The studies discussed above also considered radiological and toxicological risk acceptance guidelines for on-site workers. On-site workers are defined to be individuals in the vicinity of a facility with an evaluation distance from the facility of 100 meters in the direction of the worst-case meteorology. These guidelines are also presented in the Westinghouse Hanford Company Nonreactor Nuclear Facility Safety Analysis Manual. Their review and acceptance has been as

complete as the public guidelines. It is proposed that they be adopted for the criterion appropriate to the health and safety of workers (see Figure 2, On-site, and Figure 3).

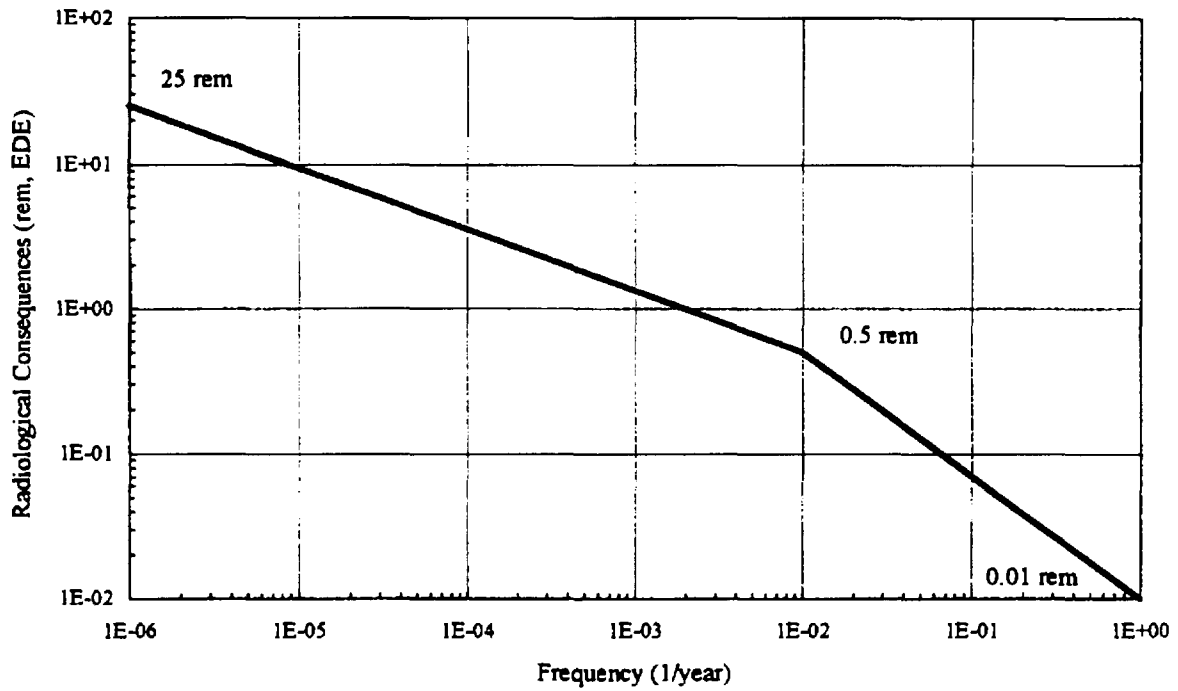
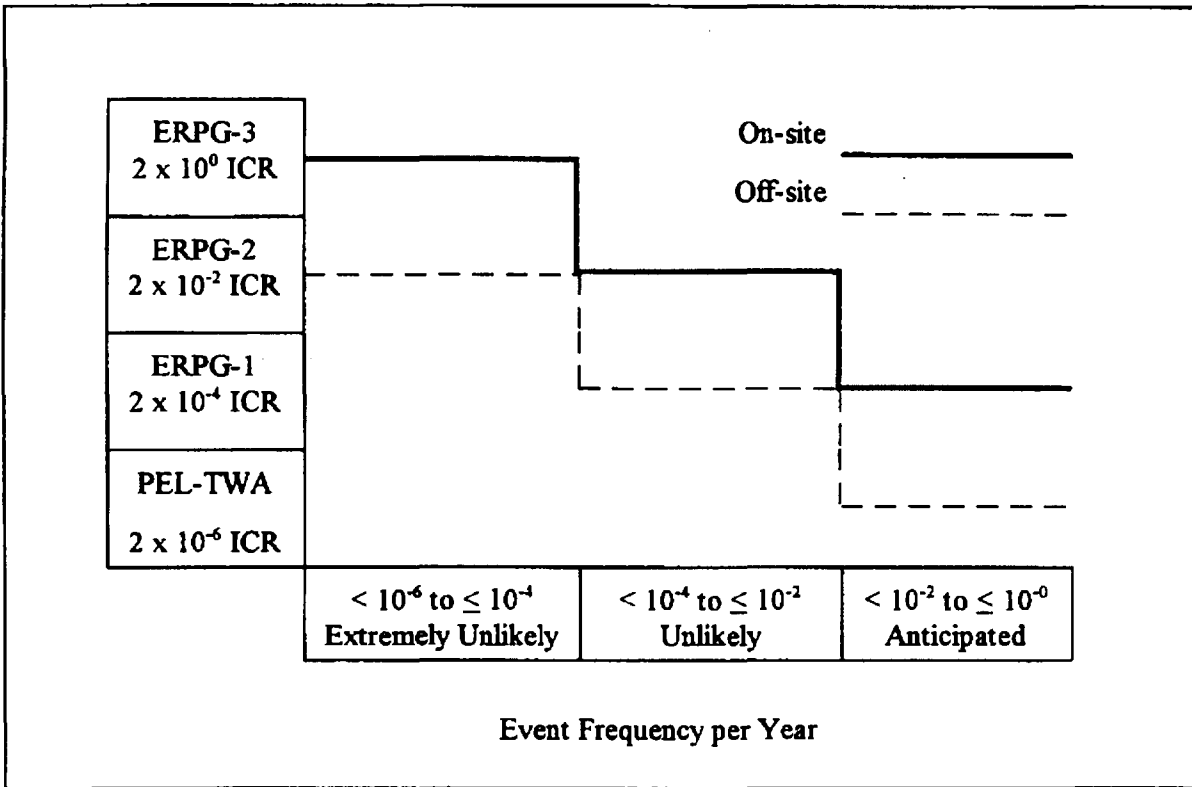

Figure 1. Off-Site Radiological Risk Acceptance Criterion



- Notes: (1) Concentration and Incremental Cancer Risk (ICR), which are presented as increasing upwards, are not to scale.
- (2) Application example: If the calculated on-site concentration is \leq ERPG-2, the permissible event frequency per annum is in the range $>10^{-4}$ to $\leq 10^{-2}$. If the calculated off-site concentration is \leq ERPG-1, the permissible event frequency per annum is in the range $>10^{-4}$ to $\leq 10^{-2}$.
- (3) This figure was extracted from the reference (WHC 1993).

Figure 2. Nonradiological Risk Acceptance Criterion

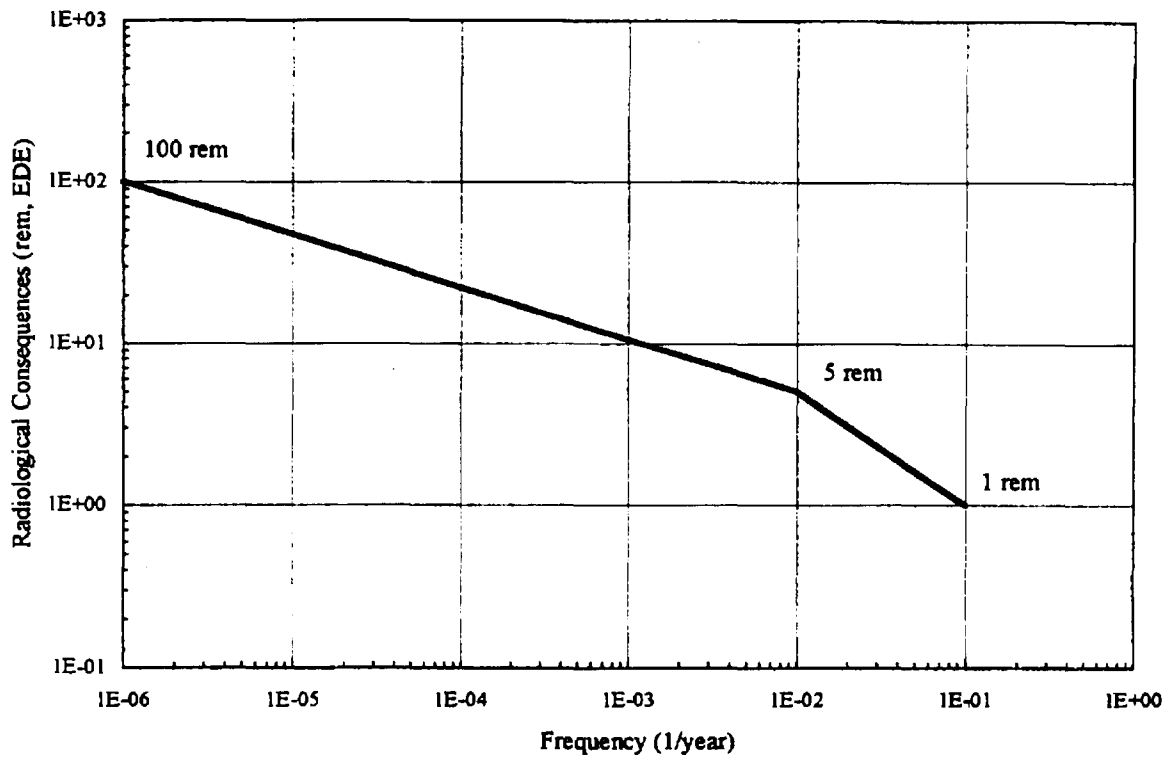

Figure 3. On-Site Radiological Risk Acceptance Criterion

4.2 ENVIRONMENTAL RISK

Risk to the environment can come from the release of radioactive or hazardous materials into the atmosphere or the ground. Environmental risk may be in the form of an impact to natural resources, usable land masses, surface water and/or ground water. Environmental contamination could be expressed in terms of the contamination per unit area of ground surface (i.e., Ci/m²), or the concentration of contamination in either surface water, ground water, or soil (i.e., Ci/m³).

An important consideration relative to environmental contamination is the cost that would be required to cleanup the contamination and restore the environment. Therefore a more uniform measure of environmental contamination will be the total cleanup costs. The cleanup costs could be expressed in terms of the cost per unit of ground surface area remediated, the cost per volume of soil remediated, or the cost per volume of water remediated. However, it appears that for a high-level criterion, the total cleanup cost may be more uniform and a better measure of the impact or insult to the environment.

An environmental risk acceptance criterion has been developed by relating the environmental impact to the cost of cleanup. The criterion is expressed in terms of the probability of exceeding a given cleanup cost. The criterion shown in Figure 4 provides the probability and frequency of exceeding a specific cleanup cost if an event that spread contamination should occur. The curves in Figure 4 were developed from information regarding cleanup of the Environmental Protection Agency Superfund sites and a review of the Record of Decision (EPA 1993) for 149 Superfund sites (see Appendix A for details). The Environmental Protection Agency (EPA 1994) estimates that of the more than 1300 Superfund sites on the National Priorities List the average total cost per site is \$22.5 million dollars, excluding the remedial investigation and feasibility study and operation and maintenance costs.

An environmental contamination complementary cumulative distribution function (CCDF) was developed by using a statistical distribution to represent the consequences (cleanup costs) from unintentional releases that would result in environmental contamination. See Appendix A, Section A.1 for the definition of a complementary cumulative distribution function. The area under a CCDF is equal to the total risk. Therefore, the area under the CCDF curve was normalized to be equal to the average Superfund site cleanup costs (\$23 million).

An exceedance frequency curve was developed from the CCDF by normalizing the average cleanup costs over a ten year period (i.e., \$2.3 million per year). Even though the event frequency and the exceedance frequency are fundamentally different, they are related (see Appendix A, Equation A-5); and for small values they are nearly the same. Therefore, for the purposes of this criterion, the exceedance frequency in Figure 4 can be considered as nearly equal to an event frequency. Thus, the criterion in Figure 4 can be used as an event frequency versus consequences (cleanup costs) space that can be used to assess acceptable risk due to events that could lead to environmental contamination.

Data for property losses from natural events were obtained, evaluated and compared to the information in Figure 4 (see Appendix A, Figure A-4). Two categories of events chosen for comparison were industry and utility fires and North Atlantic tropical storms and hurricanes. The number of events and property loss per event were evaluated in terms of a statistical distribution. This process provided the opportunity to compare the data with the proposed environmental contamination criterion (Figure 4) in the form of common CCDFs.

The environmental contamination CCDF has features that seem reasonable based on the data. First, the CCDF agreed very well with cleanup costs from 149 Superfund sites (EPA 1993). Second, the CCDF is rather flat from 1 million to 10 million dollars indicative that actions are taken to prevent possible events that could lead to contamination of the environment. Third, the flat curve is also indicative of the rather large costs involved in cleaning up environmental contamination. For example, cleaning up any environmental contamination would be expensive so that the probability of exceeding 1 million dollars in cleanup costs is not much different than the probability of exceeding 10 million dollars. Fourth, the CCDF appears not to be limited by any physical boundary such as is the case for industrial fires where the cost of property loss is limited

by the cost of industrial buildings. Rather, more like tropical storms, the cost of environmental cleanup will only be limited by the area that is contaminated. Although there was not a perfect match over the entire data set, the comparison suggests that the proposed environmental contamination criterion is reasonable. Appendix A discusses the development of the data and comparisons.

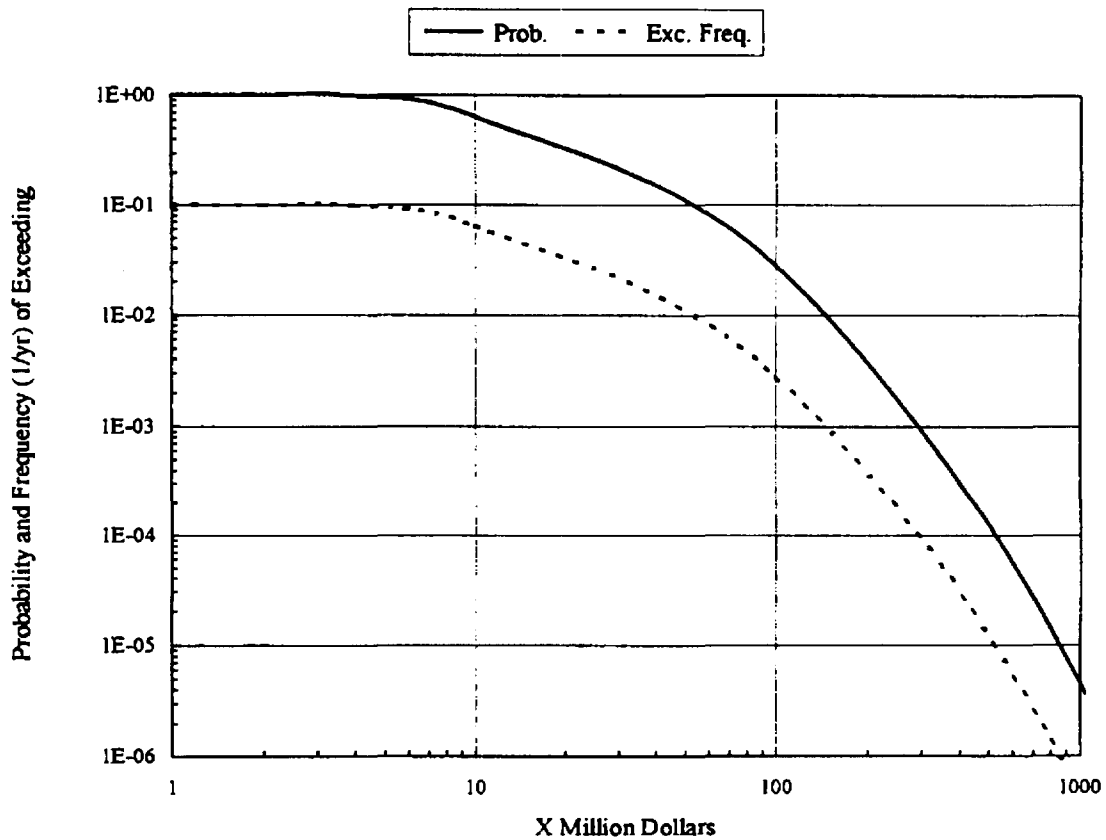

Figure 4. Environmental Risk Acceptance Criterion

4.3 PROGRAMMATIC RISK

Programmatic risk must be considered from a different perspective than health and safety risks to the public and environmental risk. Programmatic risk is related to the likelihood of success or failure and is based on an evaluation of several competing objectives with different levels of importance depending on the values of the decision maker. Programmatic risk can be related to many different performance measures. However, in the analysis that follows the discussion will be focused on programmatic risk related to cost.

The cumulative distribution function (CDF) of a statistical distribution (see Appendix A, Section A.1) is used in considering programmatic risk evaluations. It is assumed that all variables involved in evaluating or determining cost estimates are represented by distributions. Therefore, the cost estimate is also a distribution with a mean and standard deviation. The cumulative distribution function of the cost estimate specifies the probability that the cost estimate will be less than or equal to a specified value, or specifies the confidence level of the cost estimate. A general programmatic success goal was defined for the purposes of this report as a 70 to 80% probability that actual costs will be less than a value x . Risk management is then the process of identifying and managing those elements that are major contributors to the cost.

A general cumulative distribution function was developed and then scaled based on a portion of the Tank Waste Remediation Systems (TWRS) annual budget (on the order of hundreds of millions of dollars per year). A typical program on the order of 100 million dollars total (over approximately 10 years) was considered together with the general programmatic goal of a 70% to 80% confidence level. These results lead to the development a specific cumulative distribution function with a probability between 70% to 80% that the program costs would be less than or equal to \$100 million dollars. The complementary cumulative distribution function (CCDF) was then generated. The CCDF curve shown in Figure 5 is the proposed programmatic risk acceptance criterion. This criterion is intended to represent an upper bound to indicate that if the potential exists in a program for dollar losses outside of the bounds of the CCDF, then additional management effort is required to reduce the likelihood (probability) of occurrence. Cost-benefit analysis should be used to determine the most cost effective way to further reduce programmatic cost risk.

Even though this CCDF represents an upper bound, it does not imply that results falling below the curve should not trigger any management attention. The level of management action that is appropriate for results below, but reasonably close to the criterion curve should also be determined by conducting cost-benefit analysis. The TWRS system engineering effort is defining specific performance measures and methods for using these performance measures to make and document programmatic cost-benefit decisions. The system engineering methods provide guidance regarding how decisions, including those addressing risk, should be made to minimize costs and maximize benefits.

The programmatic risk criterion of Figure 5 was also compared to the CCDFs for industrial fires, tropical storms, Superfund cleanup costs, average Superfund cleanup costs, and environmental contamination (see Appendix A, Figure A-8). The programmatic cost CCDF resembles the shape of the CCDF for property loss from industrial fires in that the steep asymptote near 200 million dollars is indicative of limited available funds. However, the flatness of the programmatic costs CCDF from 1 to 60 million dollars is strictly a result of the fact that once budgeted, there is a high probability that the funds will be spent. The comparison was intended to show that in the vicinity from 10 to 100 million dollars the shape and magnitude of the programmatic cost criterion are reasonable.

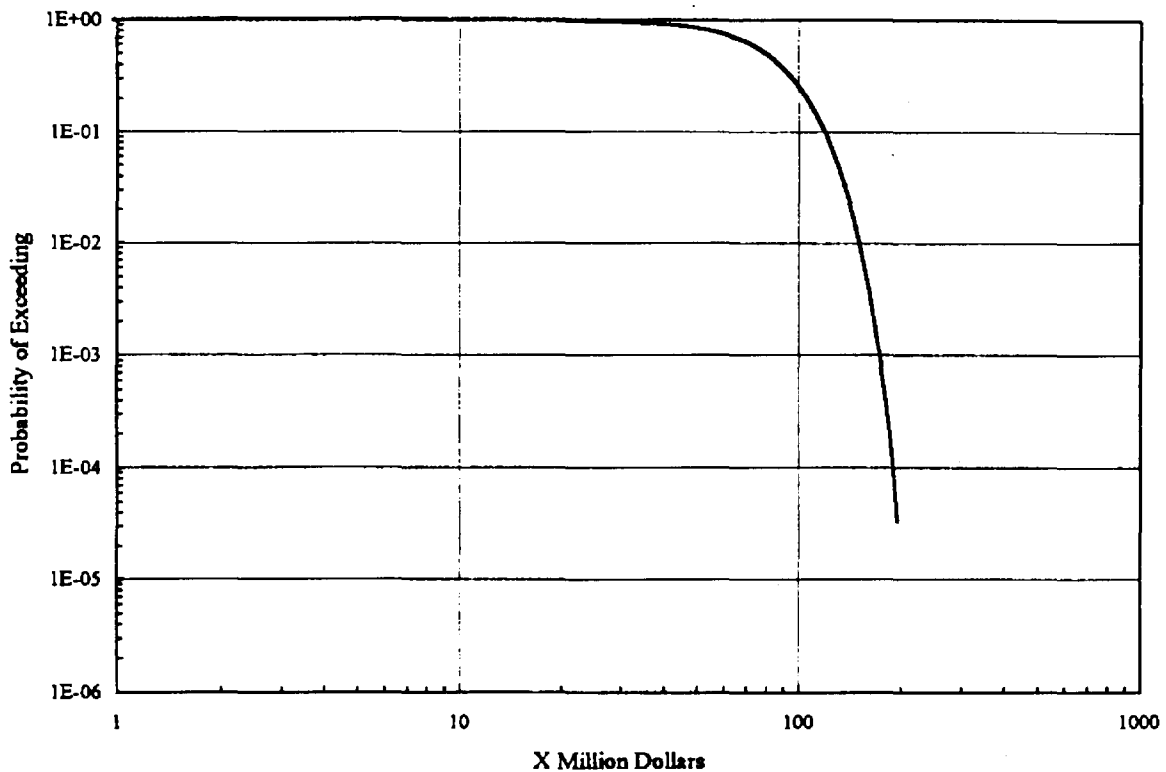

Figure 5. Programmatic Risk Acceptance Criterion

4.4 USE OF RISK ACCEPTANCE CRITERIA

In evaluating alternatives and making decisions, there are often competing objectives that must be considered. Specific criteria are usually associated with each objective and the importance given to each objective and criteria is directly related to the values of the decision makers. Often there must be a trade-off evaluation because each objective cannot be satisfied exactly. The trade-off evaluations are usually in the form of cost versus the benefit.

In the context of risk, reduced risk is the benefit. Important questions are, "How much is the reduction in risk worth?" and, "When is the risk acceptable?" Risk acceptance criteria can be very helpful in evaluating acceptable risk and determining when and if something more must be done to further reduce the risk. It must be emphasized, however, that a reduction in risk alone is not the only input in making an important decision. The objectives noted above and their importance to the decision maker must also be considered.

Any of the data from Figures 1, 2, 3, or 4 could be used to illustrate the use of risk acceptance criteria. Since the criteria for radiological, toxicological and environmental risk (Figures 1, 2, and 3) are related to the potential release of radioactive or hazardous materials from accident conditions, the criterion in Figure 1 will be used as an example. It should be remembered that the final objective of this effort is to eventually relate acceptable risk to the accuracy, uncertainty or detection levels of required characterization data. A more detailed methodology to relate the risk acceptance criteria to the TWRS waste characterization process will be developed and documented in a subsequent report.

Consider the following example where the potential exists for an accident to occur that would result in harm to the public. Suppose that the potential consequences from the event and the likelihood of the event have been qualitatively evaluated and are represented by the four States A, B, C, and D in Figure 6. The data in Figure 6 demonstrate by the error bars associated with each data point that there is uncertainty in both the determination of the consequences and the determination of the frequency of postulated events. These uncertainties must be considered in any action that may be contemplated. From a public risk perspective, based on the risk acceptance criterion, no further action would be required for the situation illustrated by State B; the risk to the public is acceptable. Clearly the situation illustrated by State A would require some preventative or mitigative action (barrier) to be taken to reduce the consequence of the event and/or the likelihood of the event.

The situations illustrated by State C and State D are not so straight forward. For these States no action may be required. State C has higher potential consequences, but lower likelihood of occurring, while State D has lower potential consequences, but higher likelihood. Considering the uncertainty in the data it may be prudent to use cost-benefit analysis to consider the most cost effective approach to reduce the consequences and/or the frequency of the events for these two states.

Another example of using Risk Acceptance Criteria is illustrated in Figure 7 where an initial state and four potential end states are graphed as a function of the costs required to reduce the risk from the initial state to the end state. Cost-benefit (reduced risk) analysis is used to determine the most cost effective way to achieve a reduction in risk. Note that in the example all of the illustrated end states are below the risk acceptance criteria. Therefore, from a risk perspective one would choose the action that achieved acceptable risk for the smallest cost (State A). However, from the perspective of a decision maker who must consider all competing objectives, one may choose, for example, State B because State B also satisfies other important objectives. This example illustrates that all objectives must be considered and all benefits evaluated as a function of cost before a specific decision can be made. However, with the risk acceptance criteria one has a method of judging acceptable risks.

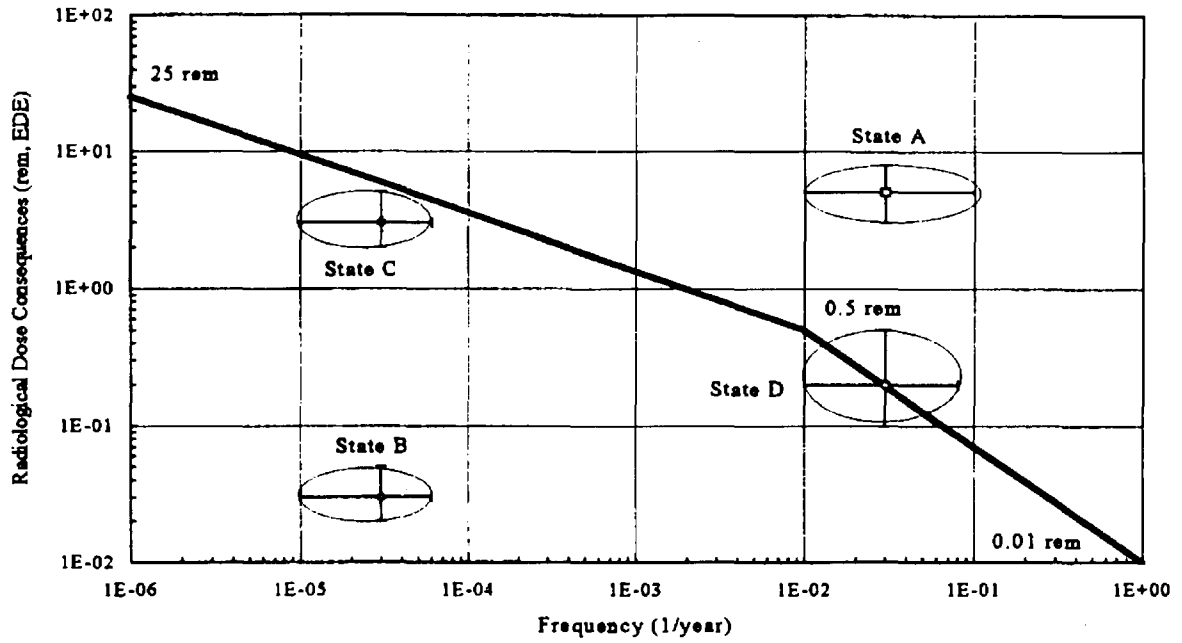

Figure 6. Illustrative Example of Using Risk Acceptance Criteria

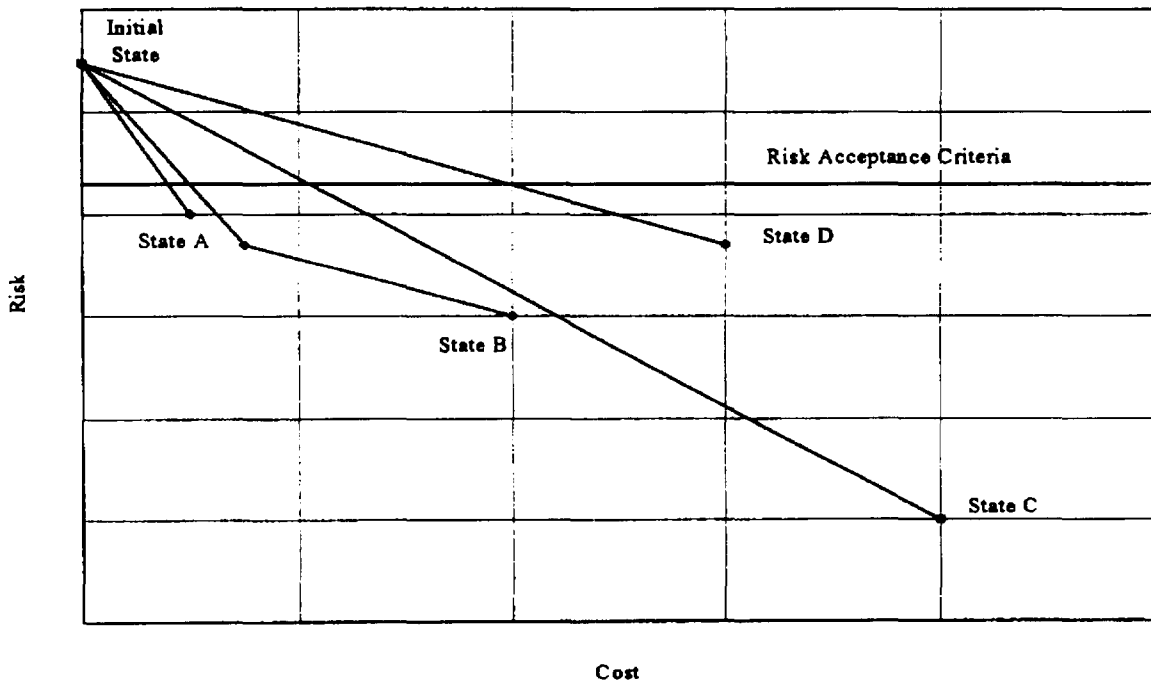

Figure 7. Example of a Cost-Reduced Risk Evaluation

5.0 CONCLUSION

The five figures presented in Section 4 of this report are the proposed TWRS Risk Acceptance Criteria. These criteria satisfy Commitment 1.20 of the TWRS Implementation Plan (DOE-RL 1994a).

6.0 REFERENCES

Acton, J. P., 1989. *Understanding Superfund: A Progress Report*. Rand Corporation, Santa Monica, CA.

Armacost, L. L., von Winterfeldt, D., Creighton, J., and Robershotte, M., 1994. Public Values Related to Decisions in the Tank Waste Remediation System Program," PNL-10107, Pacific Northwest Laboratory, Richland, Washington.

Craig, D. K., et al., 1993. "Toxic Chemical Hazard Classification and Risk Acceptance Guidelines for Use in DOE Facilities," Progress Report of the Westinghouse M&O Subcommittee on Non-Radiological Risk Acceptance Guidelines Development.

DOC 1994. "Statistical Abstract of the United States 1994, 114th Edition", U. S. Department of Commerce, Washington, D.C.

DOE 1991. Secretary of Energy Notice, "Nuclear Safety Policy," SEN-35-91, U.S. DOE.

DOE-RL 1994. "Recommendation 93-5 Implementation Plan," U.S. Department of Energy, Richland Operations Office, DOE/RL 94-0001.

DNFSB 1993. Letter, J. T. Conway, DNFSB Chairman, to The Honorable Hazel R. O'Leary, "Recommendation 93-5 To The Secretary of Energy," July 19, 1993.

EPA 1994. *National Priorities List for Uncontrolled Hazardous Waste Sites*, 40 CFR Part 300, United States Environmental Protection Agency, Washington DC.

EPA 1993. *ROD Annual Report*, Publication 9355.6-06, PB93-963349, United States Environmental Protection Agency, Office of Solid Waste and Emergency Response, Washington, DC.

Hey, B. E., Kelly, J. E., Leach, D. S., Muhlestein, L. D., and Meichle, R. H., 1992. "Application of the DOE Nuclear Safety Policy," WHC-DS-GN-RPT-30006, Rev. 0, Prepared for the U.S. Department of Energy, Westinghouse Hanford Company, Richland, Washington.

Johnson, M. E., 1994. "Tank Waste Remediation System Decisions and Risk Assessment," Prepared for the U.S. DOE, Westinghouse Hanford Company, Richland, Washington.

Kupfer, M. J., et al., 1994. "Strategy for Sampling Hanford Site Tank Wastes for Development of Disposal Technology," WHC-SD-WM-TA-154, Westinghouse Hanford Company, Richland, Washington.

US 1994. *The Total Costs of Cleaning Up Nonfederal Superfund Sites*, U. S. Congress Budget Office Report, 94-04426, Washington, DC.

WHC 1993. "Nonreactor Nuclear Facility Safety Analysis Manual," WHC-CM-4-46, Revision 3, Westinghouse Hanford Company, Richland, Washington.

WHC 1994a. "Corrective Action Management Manual," WHC-CH-1-4, Release 5, Section 3, Westinghouse Hanford Company, Richland, Washington.

APPENDIX A

DISCUSSION OF RISK PERSPECTIVES AND DEVELOPMENT OF RISK ACCEPTANCE CRITERIA

A.1 DISCUSSION OF RISK PERSPECTIVES

The definition of risk provided in Section 3.0 is a quantitative or qualitative expression of possible loss or harm that considers both the probability that a hazard will cause harm to a receptor and the consequences of that event. As noted, risk is usually defined in terms of the frequency or likelihood of an undesirable event rather than the probability.

There are two ways that risk can be considered. First, risk can be considered in terms of a group of events each with a consequence and frequency of occurrence. The product of the frequency and consequence for an event can be thought of as the individual event risk. The total risk is then taken to be the sum of the frequency - consequence pairs summed over the complete group of events. Mathematically, the total risk is given by;

$$R_T = \sum_{j=1}^N p_j C_j f_j \quad [A-1]$$

where C_j is the consequence, f_j is the frequency of the j th event, and p_j is a normalizing constant used so that risk has a consistent set of units.

The Risk Acceptance Criteria of Figure 1, in the main text, are then interpreted as follows. If the likelihood of an event is large (i.e., of the order of one chance in one to ten years; $1/\text{year}$ to $1 \times 10^{-1}/\text{year}$) then to be acceptable the consequence of the event must be small. If the likelihood of an event is small (i.e., of the order of one chance in 10,000 years to 1,000,000 years; $1 \times 10^{-4}/\text{year}$ to $1 \times 10^{-6}/\text{year}$) then a much larger consequence would be acceptable. The different slope in Figure 1 for frequencies smaller than $1 \times 10^{-2}/\text{year}$ expresses our being averse to large consequence events even though the likelihood of occurrence may be small (risk aversion). In Figure 1 the frequency is more correctly defined to be the event frequency, that is, how often might the event occur.

The other way that risk can be considered is in terms of a distribution of events each with a different consequence. The consequences represent a statistical distribution that can be represented by $g(x_j)$. If the statistical distribution is normalized to unity, then the cumulative distribution function (CDF) is defined by,

$$Pr[X < x_k] = \sum_{j=1}^k g(x_j) , \quad [A-2]$$

and, the complementary cumulative distribution function (CCDF) is defined by;

$$Pr[X > x_k] = \sum_{j=k}^N g(x_j) . \quad [A-3]$$

The cumulative distribution function is defined to be the probability that the consequence of an event will be less than x_k , while the complementary cumulative distribution function is defined to be the probability that the consequence of an event will be larger than x_k if an event occurs. Figure A-1 shows an example of a cumulative distribution function and a complementary cumulative distribution function.

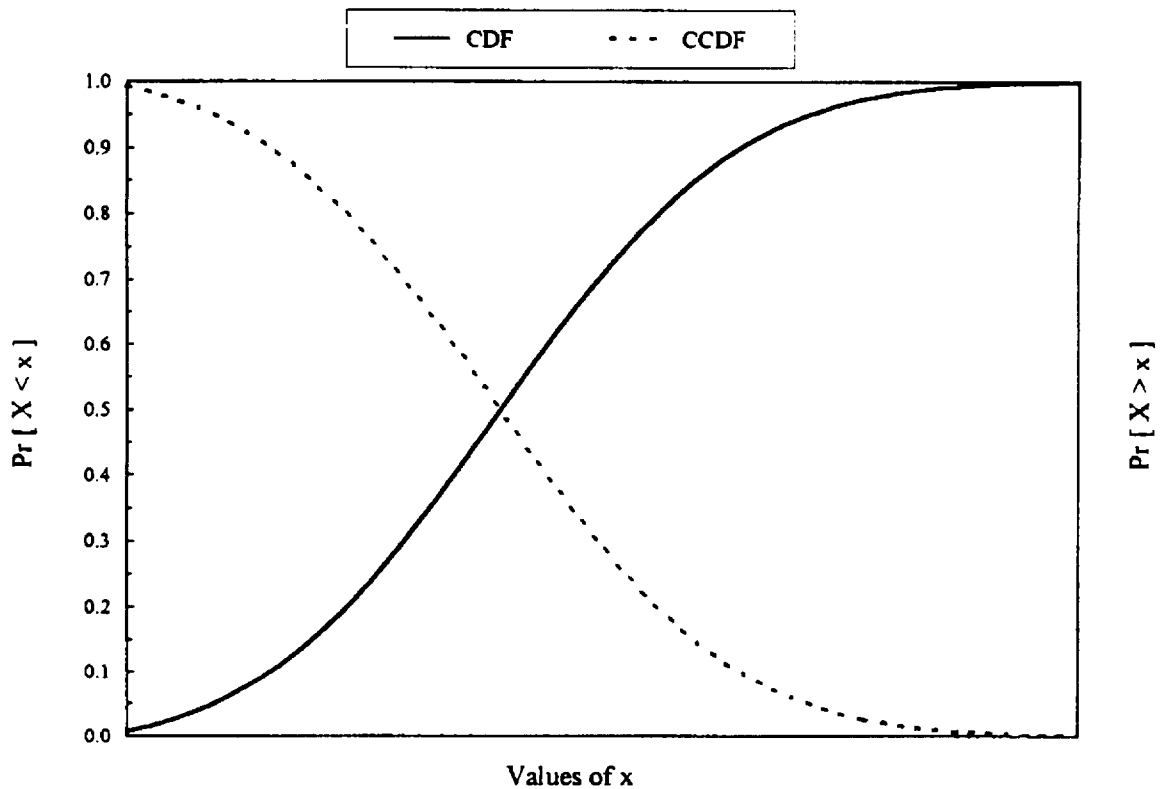

Figure A-1. Example of a Cumulative Distribution Function (CDF) and a Complementary Cumulative Distribution Function (CCDF).

Sometimes the statistical distribution function is not normalized to unity, but normalized to the average number of events per year (N/T). In this case, the complementary cumulative distribution function is defined by:

$$Fr[X > x_k] = \sum_{j=k}^N g(x_j) = \frac{N}{T} Pr[X > x_k] . \quad [A-4]$$

Here the complementary cumulative distribution function is defined to be the frequency per year that the consequence of an event will be larger than x_k . This complementary cumulative distribution function has been defined as the exceedance frequency. For small exceedance frequencies, the exceedance frequency and probability become nearly the same value.

There is a fundamental difference between the event frequency in terms of single events and the exceedance frequency. The event frequency is the likelihood that an event will occur (in events per year) with any consequence, while the exceedance frequency is the likelihood that an event will occur with consequences larger than some specified value. However, the two frequencies are related. If the consequences are rank ordered from the smallest consequence to the largest consequence, then the exceedance frequency, F_k , and event frequency, f_k , are related by the following expressions.

$$F_k = \sum_{j=k}^N f_j \quad [A-5]$$

$$f_k = F_k - F_{k-1} .$$

In this context, the total risk from all of the events is the area under the exceedance frequency curve. That is, the total risk is given by;

$$R_T = \sum_{j=1}^N p_j C_j [F_j - F_{j-1}] \quad [A-6]$$

$$= \sum_{j=1}^N p_j C_j f_j .$$

A.2 ENVIRONMENTAL RISK CRITERION

Figures 1 and 3, of the main text, are good representations of risk acceptance criteria for events that may affect the health and safety of the public and workers. Those accident sequences that release contamination via the airborne pathway that cause harm to the public and the workers would also result in contamination of the environment. If the accident sequence did not release contamination via the airborne pathway but to the soil or ground, then in the near term the public and workers would not be affected, only the environment would be contaminated.

For environmental contamination, a similar criterion as shown in Figures 1 and 3 of the main text could be used if the consequences were represented in terms of the resulting contamination per unit area. However, if the total cleanup costs are used as a measure of the impact to the environment, then the concept of an exceedance frequency appears to be more

appropriate. In this case the CCDF expresses the concept that if an event should occur what is the likelihood that the consequences (total cleanup costs) would exceed some specified value. In this case one does not have to determine the likelihood that an event would occur and contaminate the environment, but if an event did occur what is the likelihood that the cleanup costs would be larger than a specified value.

In order to evaluate the potential cost of cleaning up environmental contamination, information regarding cleanup of the Environmental Protection Agency Superfund sites was reviewed. The Environmental Protection Agency (EPA 1994, 40 CFR Part 300) estimates that the average total cost per site to cleanup Superfund sites on the National Priorities List is 22.5 million dollars, excluding the remedial investigation and feasibility study and operation and maintenance costs. In 1989 the estimated cost was 10 million dollars per site (Acton 1989). In a report to the U. S. Government, cleanup of the estimated 1300 Superfund sites was estimated at 58 million dollars (US 1994). Also, one hundred forty nine (149) Record of Decision (ROD) summary tables were reviewed (EPA 1993) and the site cleanup costs were analyzed as a statistical distribution.

To develop an environmental contamination CCDF, it was assumed that the consequences (cleanup costs) from accidents that would result in environmental contamination could be represented by a statistical distribution. A normal distribution was assumed to simplify the analysis, however, the results are not dependent on the form of the distribution chosen. From the consequence distribution, a CDF and a CCDF were developed. Recall that the area under an exceedance frequency curve is equal to the total risk, in units of consequences per year. Likewise, the area under a CCDF curve is equal to the total risk in units of consequences (probability is unitless). The area under the CCDF curve was, therefore, normalized to be equal to the average Superfund site cleanup costs (\$23 million). The developed CCDF was compared to the CCDF determined for the 149 Superfund cleanup costs noted above. The results are presented in Figure A-2. Note that the average Superfund cleanup cost, shown in Figure A-2 with appropriate error bars, is the average cleanup cost for an estimated 1300 Superfund sites, while the data points represents the cleanup cost distribution for only 149 Superfund sites. The results shown in Figure A-2 suggest that the proposed environmental contamination CCDF criteria is reasonable.

An exceedance frequency was then developed from the CCDF by normalizing the average cleanup costs over a ten year period (i.e., \$2.3 million per year). The proposed environmental contamination CCDF and exceedance frequency curve are shown together in Figure A-3 (the CCDF in Figure A-2 and Figure A-3 are the same). Even though the event frequency and the exceedance frequency are fundamentally different, they are related (Equation A-5) and for small values they are nearly the same. Therefore, for the purposes of this criterion the exceedance frequency curve in Figure A-3 can be considered as an event frequency. Thus, the criterion in Figure A-3 can be used as an event frequency versus consequences (cleanup costs) criterion to access acceptable risk due to events that could lead to environmental contamination.

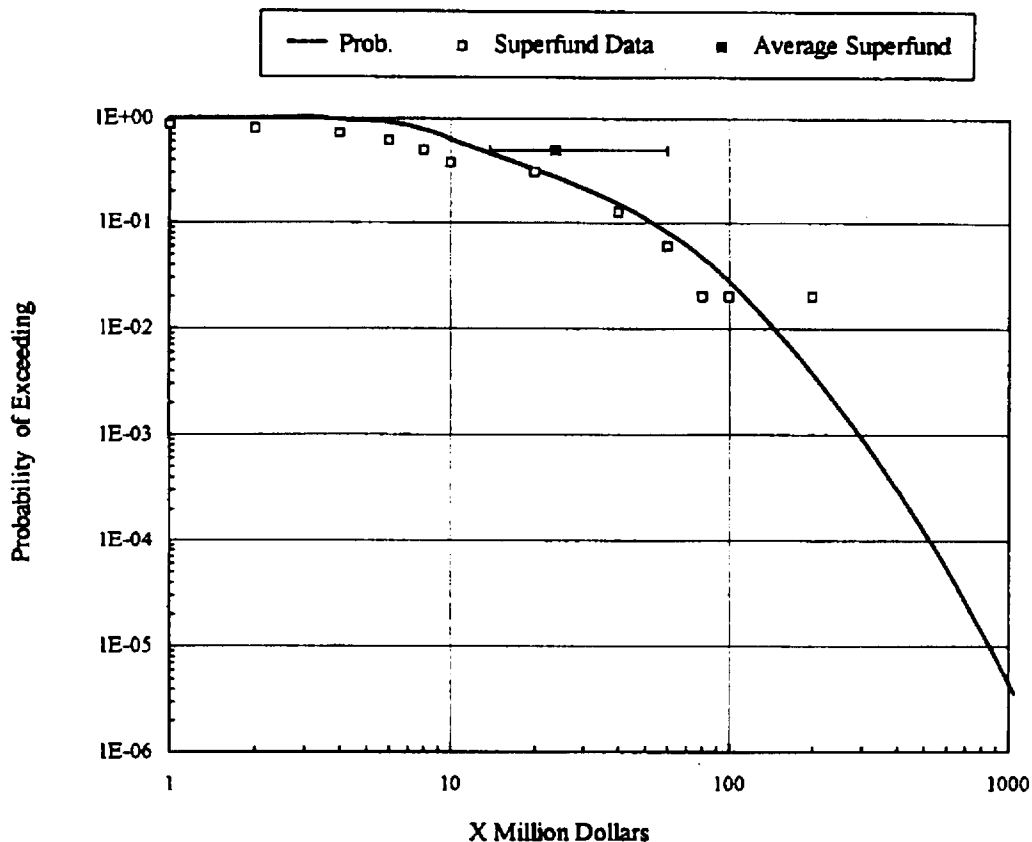

Figure A-2. Proposed Environmental Contamination CCDF Compared to the CCDF Developed from Superfund Cleanup Costs and the Average Superfund Cleanup Cost.

Other information was considered in order to support development of an environmental contamination criterion. For example, the consequences from several natural disasters were evaluated. Although any number of naturally occurring events could have been considered, two were chosen for examples. They were property loss from industry and utility fires, and property loss from North Atlantic tropical storms and hurricanes. The data were obtained from the 114th Edition of the Statistical Abstract of the United States 1994 (DOC 1994).

Both the number of events occurring each year and the total property loss each year were listed and used to provide a value of the property loss per event per year. The data were available for four years for industry and utility fires, and ten years for tropical storms and hurricanes. These data were rank ordered from the lowest to largest average property loss per event. A complementary cumulative distribution function was determined for each set of data. In order to extrapolate the data to lower probabilities, the rank-ordered data were represented by a continuous distribution function.

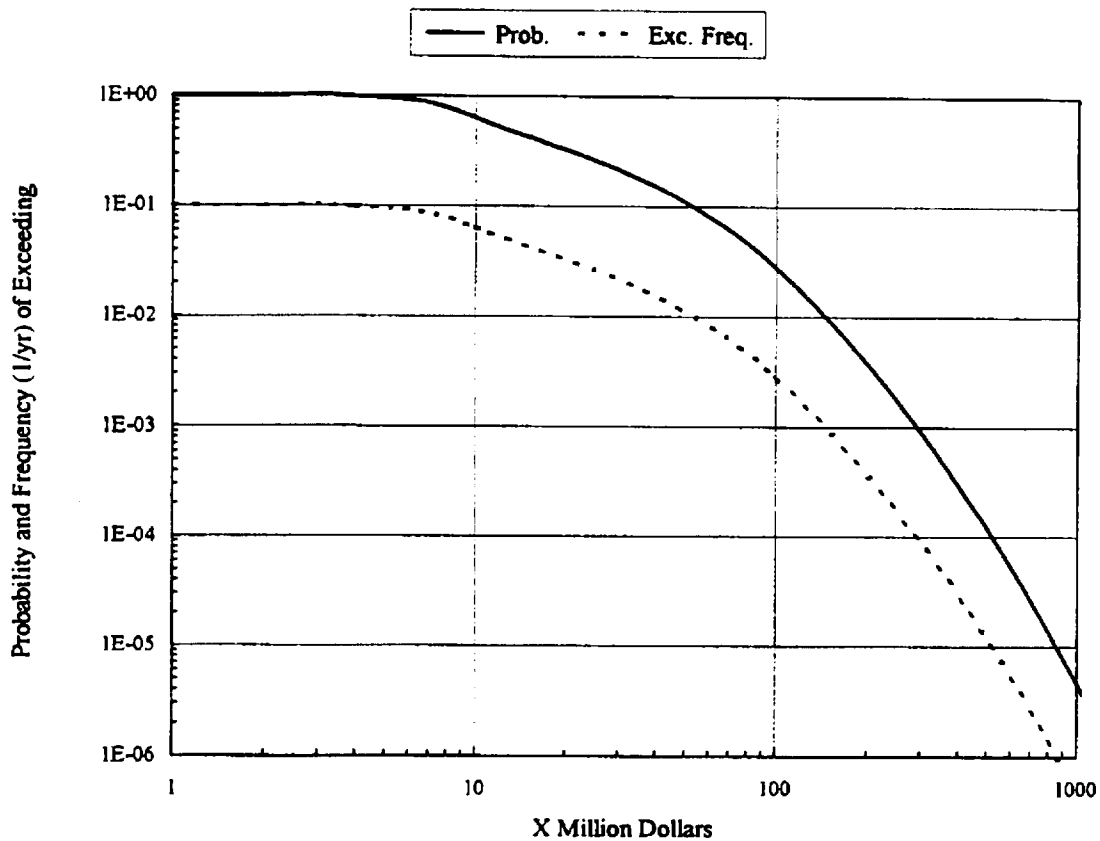

Figure A-3. Proposed Environmental Contamination CCDF and Exceedance Frequency Curve

The combined CCDFs for tropical storms, industrial fires, the cost to cleanup Superfund sites, the average Superfund cleanup cost, and the proposed environmental contamination criterion are presented in Figure A-4. The data in this figure illustrate the range of potential dollar loss for various events analyzed. There are several important observations from the data in Figure A-4 that need to be highlighted.

First, as one would expect, the probability of sustaining a large property loss from tropical storms and hurricanes is larger than the probability of sustaining a similar loss from industry fires. The property loss from industrial fires is limited by the cost of the industrial buildings. This fact is indicated by the steep slope of the curve from 50 million to 100 million dollars, and the steep asymptote beyond 100 million dollars. The CCDF for industrial fires is rather flat from 1 million to 20 million dollars principally because of fire prevention devices used in industrial buildings to prevent property loss.

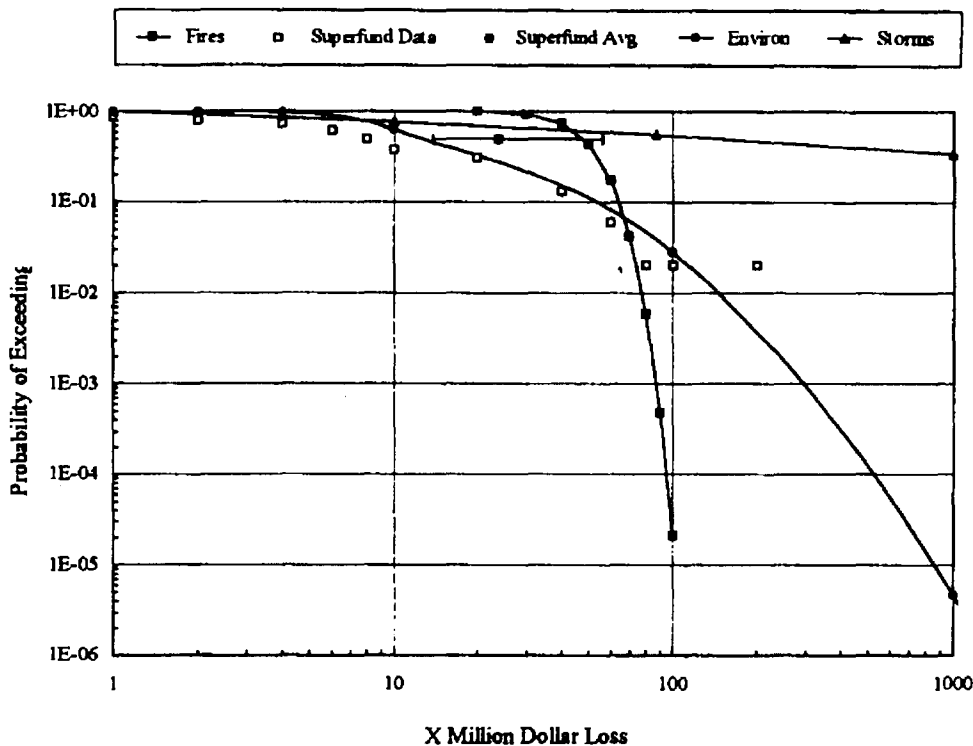

Figure A-4. CCDF Curves for Industrial Fires, Tropical Storms, Superfund Cleanup Costs, Average Superfund Cleanup Cost and Environmental Contamination.

Second, property loss from tropical storms is not limited by any physical boundary, but is widely varying due to the large area a tropical storm may cover. This is illustrated by the rather flat CCDF in Figure A-4. The probability of exceeding 10 million dollar loss is 0.9 while the probability of exceedance 100 million dollar loss is 0.6.

Third, the proposed environmental contamination CCDF has features that seem reasonable based on other data. (1) The curve is rather flat from 1 million to 10 million dollars. The flat curve is indicative of actions taken to prevent possible events that could lead to contamination of the environment. (2) The flat curve is also indicative of the costs involved in cleaning up environmental contamination. The probability of exceeding 1 million dollars in cleanup costs is not much different than the probability of exceeding 10 million dollars. (3) The environmental contamination CCDF appears not to be limited by a ceiling, such as is the case for industrial fires, but would depend on the total area of the contamination (much like damage from tropical storms).

From the above discussion, the proposed Environmental Risk Acceptance Criterion in Figure A-3 for environmental contamination based on cleanup costs seems reasonable.

A.3 PROGRAMMATIC RISK CRITERION

Programmatic risk must be considered from a different perspective than health and safety risks to the public and workers and environmental risk. Programmatic risk relates to the likelihood of success or failure and is based on an evaluation of several competing objectives with different levels of importance depending on the values of the decision maker. Programmatic risk can be related to many different performance measures. In the analysis that follows the discussion will be focused on programmatic risk related to cost and schedule. It will also be assumed that any schedule impacts can be directly related to an impact on cost.

The cumulative distribution function (CDF) is usually used in relation to programmatic risk evaluations. The basic assumption is that all variables involved in evaluating or determining a cost are represented by distributions, and therefore the end product cost is also a distribution about a mean with a standard deviation and a variance. The CDF of the cost distribution then represents the probability (or likelihood) that the actual costs will be less than a specified value. Sometimes the results of a CDF cost distribution are stated as the confidence level of the costs. In this analysis a programmatic goal was defined as a 70% to 80% probability that actual costs will be less than a value x . Stated differently, there should be a 70% to 80% confidence level that the actual costs will be less than a value x . The objective then is to identify those elements that contribute to the cost, and specifically those elements that have the largest impact on the total costs. These elements are then managed such that their impact on the total cost is minimized (i.e., their distribution is well defined with a minimum standard deviation). This effort is termed risk management.

An example cost CDF is shown in Figure A-5. The programmatic goal is illustrated by the horizontal lines between 70% and 80% with a dashed line at 75%. Figure A-5 defines the programmatic goal as a 70% to 80% probability that actual costs will be less than a value x , or a 70% to 80% confidence level of maintaining actual costs less than a value x . Although the programmatic goal is quite general, a specific upper bound in terms of cost impacts will next be determined.

The Tank Waste Remediation Systems (TWRS) annual budget is on the order of hundreds of millions of dollars per year and consists of several major programs. Assume that a typical program of interest is on the order of 100 million dollars. The programmatic goal is applied as follows. The program should be managed such that there is a 70% to 80% probability that actual costs over the lifetime of a project or activity will be less than or equal to the budgeted costs of 100 million dollars. Thus, the results of Figure A-5 are scaled such that the specific value for x is 100 million dollars. These results are shown in Figure A-6.

The complement of the CDF in Figure A-6 is graphed in Figure A-7 as the probability of exceeding x million dollar loss. The curve in Figure A-7 is only intended to present an upper bound to indicate that if the potential exists in a project or activity for dollar losses on the order of 100 million dollars then additional management effort is required to reduce the likelihood (probability) of occurrence. In all cases dealing with programmatic risks, the source of the risk needs to be identified and managed using cost-benefit analysis.

Table 2: Evaluation of Main (234-5Z, 236-Z and 242-Z) Buildings and 2736-Z Storage Complex (2736-Z, 2736-ZA and 2736-ZB) for Conformance with the Ventilation Requirements of DOE Order 6430.1A and Invoked Consensus Standards (Sheet 17 of 24)

APPLICABLE SECTION	ITEM NUMBER/CRITERIA	CONFORMANCE	
		MAIN BUILDINGS	STORAGE COMPLEX
	shall be installed outside the cell and sealed in an acceptable enclosure for direct maintenance.		
	<ul style="list-style-type: none"> All exhaust systems shall have monitors that provide an alarm if the concentration of the hazardous material in the exhaust exceeds specified limits. 	No	N/A
	In facilities where plutonium or enriched uranium is processed, the following additional requirements shall be met:		
	<ul style="list-style-type: none"> Wherever possible, the designer shall provide enclosures for confining the process work on plutonium and enriched uranium. Design criteria for enclosures of radioactive and other hazardous materials are provided in Section 1161, Enclosures. 	Yes	Yes
	<ul style="list-style-type: none"> When these confinement enclosures are specified and designed, consideration shall be given to whether room ventilation air can be recirculated. If a recirculation ventilation system is provided, the design shall provide a suitable means for switching from the recirculation mode to a once-through ventilation system. 	N/A	Yes
	<ul style="list-style-type: none"> A safety analysis under DOE direction shall establish the minimum acceptable performance requirements for the ventilation system and the response requirements of system components, instrumentation, and controls under normal operations, anticipated operational occurrences, and DBA conditions. 	Yes	Yes
	The safety analysis shall determine systems requirements such as the need for redundant components, emergency power for fans, dampers, special filters, and fail-safe valve/damper positions.	Yes	Yes
	The safety analysis and the guidelines provided by the cognizant DOE authority shall determine the type of exhaust filtration required for any area of the facility during normal operations, anticipated operational occurrences, and DBA conditions.	Yes	Yes
	<ul style="list-style-type: none"> If advantageous to operations, maintenance, or emergency personnel, the ventilation system shall have provisions for independent shutdown. 	Yes	Yes

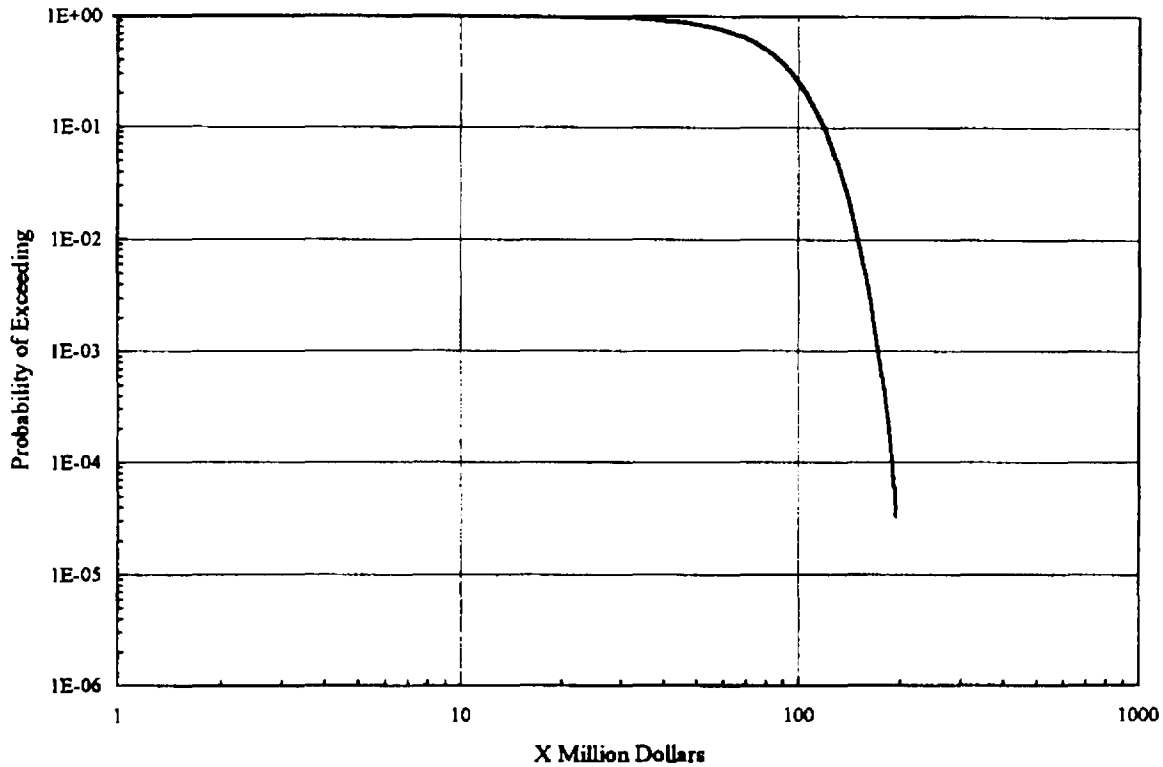

Figure A-7. Complementary Cumulative Distribution Function for Programmatic Costs

In Figure A-8 the programmatic risk criterion of Figure A-7 is added to the data graphed in Figure A-4. The results in Figure A-8 compare the CCDFs for industrial fires, tropical storms, Superfund cleanup costs, average Superfund cleanup costs, environmental contamination and programmatic costs. The programmatic cost CCDF resembles the shape of the CCDF for property loss from industrial fires. Just as the property loss from industrial fires is limited by the total cost of industrial buildings, programmatic costs are limited by the scarcity of available funds. Limited available funding is the reason for the steep asymptote near 200 million dollars. However, the flatness of the programmatic costs CCDF from 1 to 60 million dollars is strictly a result of the fact that once budgeted, there is a high probability that the funds will be spent. The comparison in Figure A-8 is intended to show that in the vicinity of 10 to 100 million dollars the shape and magnitude of the programmatic cost criterion are reasonable.

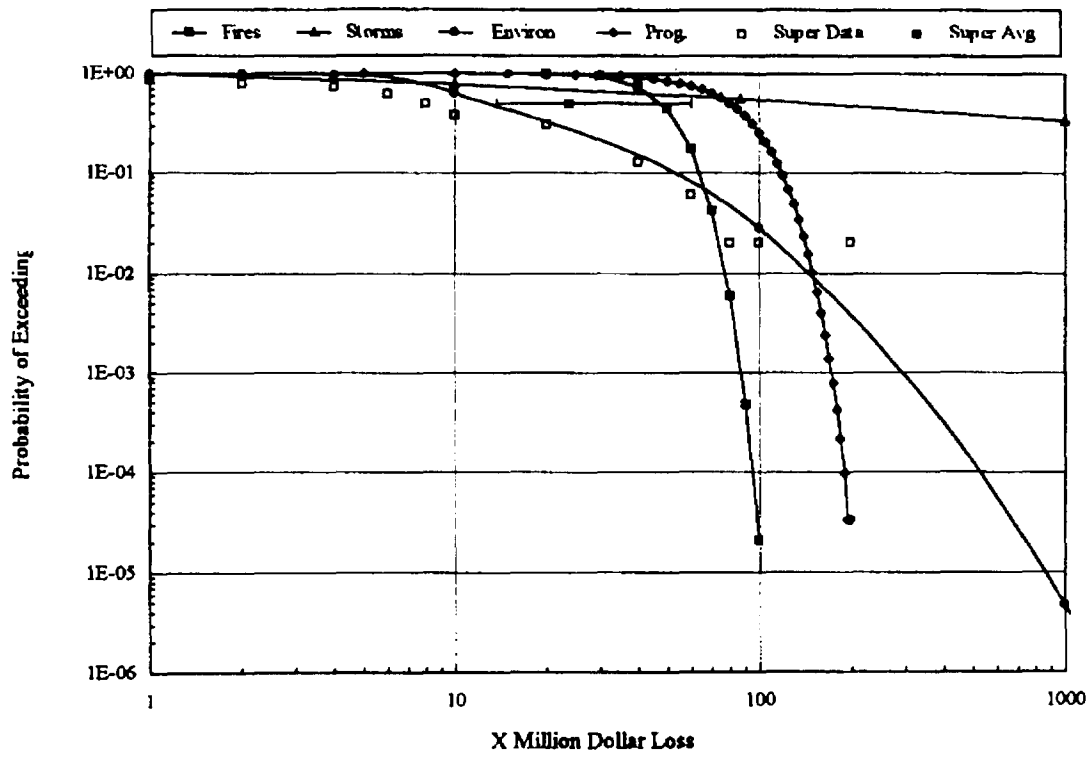

Figure A-8. Comparison of Complementary Cumulative Distribution Functions



Department of Energy

Richland Operations Office
P.O. Box 550
Richland, Washington 99352

SEP 29 1995

95-TSD-123

The Honorable John T. Conway
Chairman
Defense Nuclear Facilities Safety Board
Suite 700
625 Indiana Avenue, NW
Washington, D.C. 20004

Dear Mr. Conway:

TRANSMITTAL DOCUMENTATION FOR CLOSURE OF DEFENSE NUCLEAR FACILITY SAFETY BOARD (DNFSB) 93-5 COMMITMENTS 1.21.8 AND 2.1

This letter is to advise the DNFSB that the U. S. Department of Energy, Richland Operations Office (RL), has accepted the attached Data Quality Objectives (DQO) document. This document is transmitted to close the following two DNFSB 93-5 Commitments:

1.21.8, "In tank Generic Vapor DQO," (Attachment I: Data Quality Objectives for Generic In-Tank Health and Safety Vapor Issue Resolution); and

2.01, "DQOs for all Six Safety Issues," (NOTE: The six safety issues include: ferrocyanide, organic, vapor, flammability, criticality, and safety screening. The need for a Criticality DQO was removed when the Criticality USQ was closed. However analysis for fissile content is included in the previously transmitted Safety Screening DQO. The DQOs for the ferrocyanide, organic, and flammability issues were also transmitted to the DNFSB on September 12, 1995) The enclosed Vapor DQO closes the one remaining commitment 2.1 item.

The DQO is approved for use at this time. This approval is contingent upon the incorporation of DOE "Hold Point" comments as agreed to by the contractor in the attachments. As per regulatory guidance, the DQO process is designed to be dynamic. This DQO document may be revised in the near-future to accommodate the evolution of the program.

Honorable John T. Conway
95-TSD-123

-2-

SEP 29 1995

If you have any questions, please contact me on (509) 376-4550.

Sincerely,



Mary F. Jarvis, Project Director
Tank Safety Analysis Division

TSD:MFJ

Attachments

cc w/o attaches:

T. P. Grumbly, EM-1, HQ
M. Hunemuller, EM-38, HQ
C. S. O'Dell, EM-37, HQ
S. P. Cowan, EM-30, HQ
J. V. Antizzo, EM-37, HQ

ENGINEERING CHANGE NOTICE

1. ECN 185680

Proj.
ECN

2. ECN Category (mark one) Supplemental <input type="checkbox"/> Direct Revision <input checked="" type="checkbox"/> Change ECN <input type="checkbox"/> Temporary <input type="checkbox"/> Standby <input type="checkbox"/> Supersedure <input type="checkbox"/> Cancel/Void <input type="checkbox"/>		3. Originator's Name, Organization, MSIN, and Telephone No. Osborne, J. W. 74210, S7-15, 373-5379		3a. USQ Required? <input type="checkbox"/> Yes <input checked="" type="checkbox"/> No		4. Date April 28, 1995	
		5. Project Title/No./Work Order No. DQOs for Generic In-Tank Health and Safety Vapor Issue Resolution/WHC-SD-WM-DQO-002 Rev. 1		6. Bldg./Sys./Fac. No. N/A		7. Approval Designator N/A	
		8. Document Numbers Changed by this ECN (includes sheet no. and rev.) WHC-SD-WM-DQO-002, Rev. 0		9. Related ECN No(s). N/A		10. Related PO No. N/A	
11a. Modification Work <input type="checkbox"/> Yes (fill out Blk. 11b) <input checked="" type="checkbox"/> No (NA Blks. 11b, 11c, 11d)		11b. Work Package No. N/A	11c. Modification Work Complete N/A _____ Cog. Engineer Signature & Date		11d. Restored to Original Condition (Temp. or Standby ECN only) N/A _____ Cog. Engineer Signature & Date		
12. Description of Change Reissue as Rev 1, in its entirety with addition of Attachment A.							
13a. Justification (mark one) Criteria Change <input checked="" type="checkbox"/> Design Improvement <input type="checkbox"/> Environmental <input type="checkbox"/> Facility Deactivation <input type="checkbox"/> As-Found <input type="checkbox"/> Facilitate Const <input type="checkbox"/> Const. Error/Omission <input type="checkbox"/> Design Error/Omission <input type="checkbox"/>							
13b. Justification Details Document revision was done to reestablish a current baseline, and to discuss through Attachment A, pending revised DQO strategy.							
14. Distribution (include name, MSIN, and no. of copies) See Distribution Sheet						RELEASE STAMP OFFICIAL RELEASE BY WHC DATE APR 28 1995 SA 4	

RELEASE AUTHORIZATION

Document Number: WHC-SD-WM-DQO-002, REV 1

Document Title: Data Quality Objectives for Generic In-Tank Health and Safety Vapor Issue Resolution

Release Date: 4/28/95

This document was reviewed following the procedures described in WHC-CM-3-4 and is:

APPROVED FOR PUBLIC RELEASE

WHC Information Release Administration Specialist:

Kara M. Broz

April 28, 1995

TRADEMARK DISCLAIMER. Reference herein to any specific commercial product, process, or service by trade name, trademark, manufacturer, or otherwise, does not necessarily constitute or imply its endorsement, recommendation, or favoring by the United States Government or any agency thereof or its contractors or subcontractors.

This report has been reproduced from the best available copy. Available in paper copy and microfiche. Printed in the United States of America. Available to the U.S. Department of Energy and its contractors from:

U.S. Department of Energy
Office of Scientific and Technical Information (OSTI)
P.O. Box 62
Oak Ridge, TN 37831
Telephone: (615) 576-8401

Available to the public from: U.S. Department of Commerce
National Technical Information Service (NTIS)
5285 Port Royal Road
Springfield, VA 22161
Telephone: (703) 487-4650

SUPPORTING DOCUMENT

1. Total Pages **80**

2. Title

Data Quality Objectives for Generic In-Tank Health and Safety Vapor Issue Resolution

3. Number

WHC-SD-WM-DQO-002

4. Rev No.

1

5. Key Words

Data Quality Objectives/Decision Rules/Signature Characterization/Adaptive Analysis Strategy

6. Author

Name: J. W. Osborne

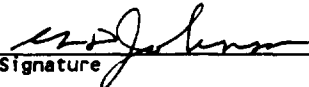
Signature

Organization/Charge Code **74210/N4A2K**

7. Abstract

The document describes the data quality objectives developed for the generic problem of tank vapor characterization.

8. RELEASE STAMP

OFFICIAL RELEASE
BY WHC
DATE **APR 28 1995**
STAY





**DATA QUALITY OBJECTIVES
FOR
GENERIC IN-TANK HEALTH AND SAFETY VAPOR ISSUE RESOLUTION**

April 1995

Westinghouse Hanford Company

J. W. Osborne
J. L. Huckaby
E. R. Hewitt

Pacific Northwest Laboratory

C. M. Anderson
D. D. Mahlum
B. A. Pulsipher
J. Y. Young

TABLE OF CONTENTS

EXECUTIVE SUMMARY vi

1.0 INTRODUCTION 1

2.0 DQO STEP 1: STATE THE PROBLEM 3

 2.1 BACKGROUND AND SCOPE 3

 2.2 PROBLEM STATEMENTS 4

 2.2.1 Flammability Problem 4

 2.2.2 Toxicity Problem 4

 2.2.3 Approach to Problem resolution 4

 2.3 DQO PLANNING PARTICIPANTS 4

3.0 DQO STEPS 2 & 3: IDENTIFY THE DECISIONS TO BE MADE AND INPUTS
 TO THE DECISION 7

 3.1 FLAMMABILITY DECISION 7

 3.2 TOXICITY DECISION 7

 3.3 INPUTS TO THE DECISION 7

 3.3.1 Flammability Decision Inputs 7

 3.3.2 Toxicity decision Inputs 8

 3.3.3 Development of Consensus Exposure Standards 8

4.0 DQO STEP 4: DEFINE STUDY BOUNDARIES 10

5.0 DQO STEPS 5: DECISION RULES 11

 5.1 FLAMMABILITY DECISION RULE 11

TABLE OF CONTENTS (continued)

5.2 TOXICITY DECISION RULE 12

5.3 DECISION RULE FOR SIGNATURE CHARACTERIZATION OF
NON-WATCH LIST TANKS 12

6.0 DQO STEP 6: LIMITS ON DECISION ERRORS 15

6.1 DEVELOPMENT OF FLAMMABILITY DECISION ERROR LIMITS 15

6.2 DEVELOPMENT OF TOXICITY DECISION ERROR LIMITS 16

7.0 SAMPLING AND ANALYSIS DESIGNS FOR OBTAINING DATA 19

7.1 STATISTICAL TERMINOLOGY 19

7.2 DESIGN ASSUMPTIONS 19

7.3 SELECT THE APPROPRIATE STATISTICAL TEST 19

7.4 OBTAIN PERTINENT ESTIMATES OF UNCERTAINTY 20

7.5 POWER ANALYSIS 21

7.6 VAPOR SAMPLE ACQUISITION METHODS 21

7.7 ADAPTIVE ANALYSIS STRATEGY 22

8.0 REFERENCES 24

LIST OF TABLES

2-1 Invited Participants in the DQO Development Effort 6

6-1 Desired Performance for the Flammability Decision 16

6-2 Desired Performance for the Toxicity Decision: Average Concentration of
Confirmed/Suspected Human (Class A1/A2) Carcinogenic, Teratogenic or
Mutagenic Constituents 17

6-3 Desired Performance for the Toxicity Decision: Systemic Toxicant
Constituents 18

6-4 Desired Performance for the Toxicity Decision: Irritant Constituents 18

TABLE OF CONTENTS (continued)

5.2 TOXICITY DECISION RULE 12

5.3 DECISION RULE FOR SIGNATURE CHARACTERIZATION OF
NON-WATCH LIST TANKS 12

6.0 DQO STEP 6: LIMITS ON DECISION ERRORS 15

6.1 DEVELOPMENT OF FLAMMABILITY DECISION ERROR LIMITS 15

6.2 DEVELOPMENT OF TOXICITY DECISION ERROR LIMITS 16

7.0 SAMPLING AND ANALYSIS DESIGNS FOR OBTAINING DATA 19

7.1 STATISTICAL TERMINOLOGY 19

7.2 DESIGN ASSUMPTIONS 19

7.3 SELECT THE APPROPRIATE STATISTICAL TEST 19

7.4 OBTAIN PERTINENT ESTIMATES OF UNCERTAINTY 20

7.5 POWER ANALYSIS 21

7.6 VAPOR SAMPLE ACQUISITION METHODS 21

7.7 ADAPTIVE ANALYSIS STRATEGY 22

8.0 REFERENCES 24

LIST OF TABLES

2-1 Invited Participants in the DQO Development Effort 6

6-1 Desired Performance for the Flammability Decision 16

6-2 Desired Performance for the Toxicity Decision: Average Concentration of
Confirmed/Suspected Human (Class A1/A2) Carcinogenic, Teratogenic or
Mutagenic Constituents 17

6-3 Desired Performance for the Toxicity Decision: Systemic Toxicant
Constituents 18

6-4 Desired Performance for the Toxicity Decision: Irritant Constituents 18



LIST OF FIGURES

1 Flammability Decision Logic Diagram 13
2 Toxicity Decision Logic Diagram 14

LIST OF ACRONYMS

ACGIH	American Conference of Governmental Industrial Hygienists
AIHA	American Industrial Hygiene Association
CES	Consensus Exposure Standard
CGM	Combustible Gas Meter
DOE	U.S. Department of Energy
DOE-RL	U.S. Department of Energy - Richland Operations Office
DQO	Data Quality Objectives
ISS	In Situ Sampling
LFL	Lower Flammability Limit
NIOSH	National Institute of Occupational Safety and Health
OSHA	Occupational Safety and Health Administration
OVS	OSHA Versatile Sampler
PEL	Permissible Exposure Limit
REL	Recommended Exposure Limit
SUMMA®	Registered Trademark for Passivated Stainless Steel Canister
TLV	Threshold Limit Value
TRP	Toxicology Review Panel
USEPA	U. S. Environmental Protection Agency
VSS	Vapor Sampling System
WEEL	Workplace Environmental Exposure Level
WHC	Westinghouse Hanford Company
WDOE	Washington State Department of Ecology

LIST OF ACRONYMS

ACGIH	American Conference of Governmental Industrial Hygienists
AIHA	American Industrial Hygiene Association
CES	Consensus Exposure Standard
CGM	Combustible Gas Meter
DOE	U.S. Department of Energy
DOE-RL	U.S. Department of Energy - Richland Operations Office
DQO	Data Quality Objectives
ISS	In Situ Sampling
LFL	Lower Flammability Limit
NIOSH	National Institute of Occupational Safety and Health
OSHA	Occupational Safety and Health Administration
OVS	OSHA Versatile Sampler
PEL	Permissible Exposure Limit
REL	Recommended Exposure Limit
SUMMA®	Registered Trademark for Passivated Stainless Steel Canister
TLV	Threshold Limit Value
TRP	Toxicology Review Panel
USEPA	U. S. Environmental Protection Agency
VSS	Vapor Sampling System
WEEL	Workplace Environmental Exposure Level
WHC	Westinghouse Hanford Company
WDOE	Washington State Department of Ecology

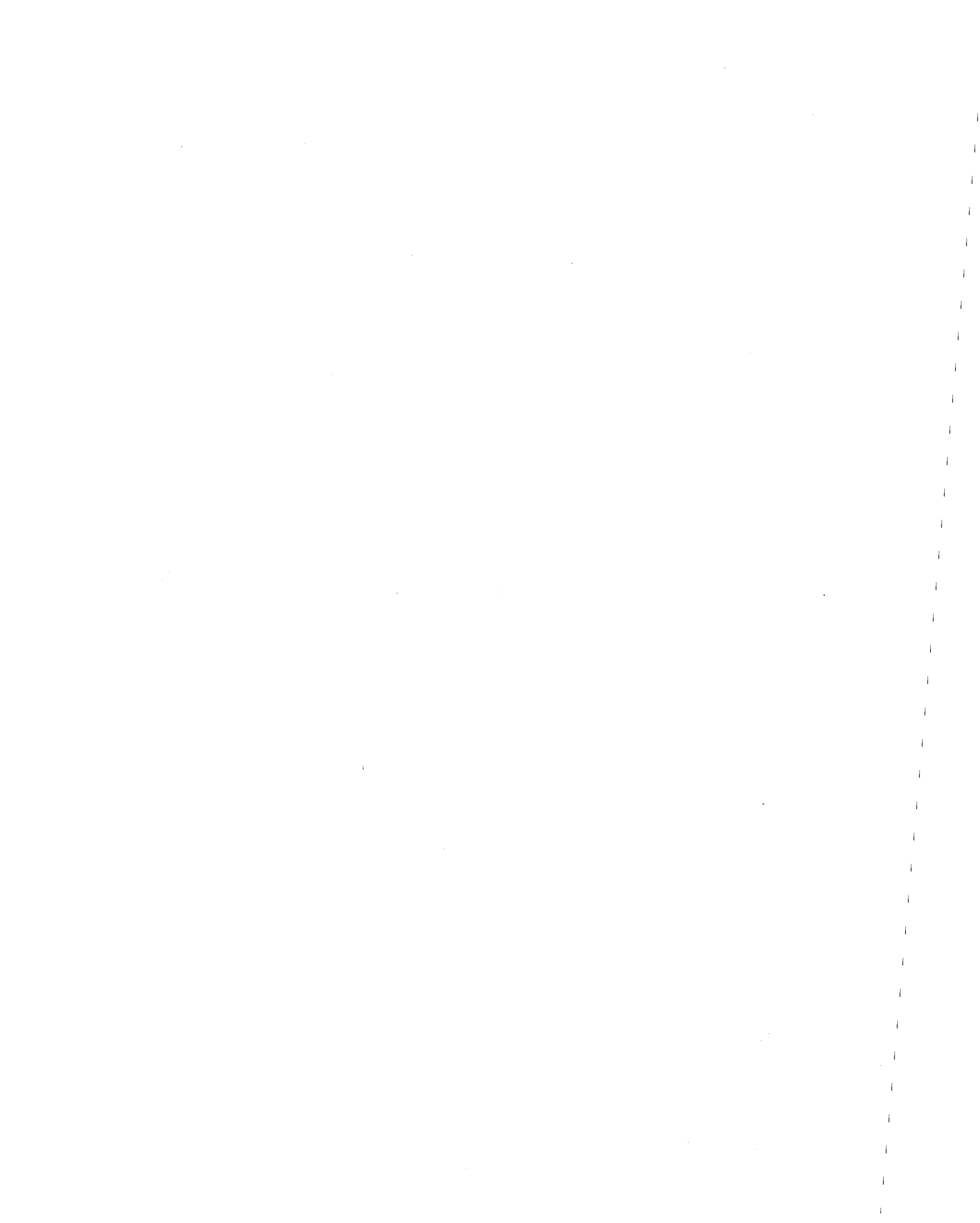

DATA QUALITY OBJECTIVES FOR GENERIC TANK VAPOR ISSUE RESOLUTION

EXECUTIVE SUMMARY

Data Quality Objectives (DQOs) for generic tank vapor and gas sampling were developed in a series of four facilitated meetings and one stakeholder review session, using the most recent U. S. Environmental Protection Agency (USEPA) DQO guidelines. These meetings elicited DQOs for two major vapor problem areas: flammability and toxicity. What follows is a summary of the outputs of the planning team for each of the seven steps of the DQO process. More details regarding the rationale for each of the DQO planning outputs are contained in the DQO document that follows this summary.

Step 1. Problem Statement

Two problems were: 1) potential flammability of gases and vapors in waste storage tanks and 2) potential worker health and safety hazards associated with the toxicity of constituents in any fugitive vapor emissions from these tanks. Previous work reports the presence of a fog in some tanks, and the fuel content of the tank gases and vapors may be too high to permit work in these tanks. Numerous reports of adverse health effects associated with vapor exposures in and around tank farms have been made by workers. Confirmed symptoms from these exposure incidents include headaches, burning sensations in nose and throat, nausea, and impaired pulmonary function.

Data are needed to identify and quantify constituents of the tank headspaces to address potential vapor toxicity. If any compounds of toxicological interest are identified in the tank headspace, industrial hygienists can use this information to assess "worst-case" worker exposure levels and focus their industrial hygiene monitoring strategy on these target compounds. Final recommendations on the required level of personal protective equipment will be based on the worker breathing zone levels of these chemicals. The ultimate goal is to provide a safe and healthful workplace in the tank farms complex.

Resolution of these problems involves a sequence of sampling events. The first sampling event assesses flammability of the volatile organic vapor, ammonia, methane, and other flammable gases present in the tank headspace. If the flammability assessment results are acceptable then special vapor sampling equipment will be installed in the tank. This equipment will be used in subsequent sampling events to: 1) establish concentrations of all flammable headspace constituents; 2) identify compounds of toxicological concern; and 3) quantify compounds of toxicological concern.

Step 2. Decision Statements

A. Flammability Decision

If the total fuel content of the headspace is $\geq 20\%$ of the lower flammability limit (LFL), then work must stop until further authorization is given by management.

B. Toxicity Decision

If any compounds with toxicological properties exceed their recommended levels inside the tank headspace, then advise Health and Safety. Guideline levels are:

- 10% of the appropriate Consensus Exposure Standard (CES)* concentration for known or suspected human carcinogens, teratogens and mutagens
- 50% of the appropriate CES concentration for non-carcinogens, non-teratogens and non-mutagens, or simple irritants.

Step 3. Inputs to the Decision

- Identification and quantification of flammable constituents in the headspace
- Temperature of the headspace
- Identification and quantification of compounds of toxicological importance
- Understanding of the toxicological effects of these compounds and the CES for each constituent of concern.

Step 4. Boundaries of the Study

The spatial boundaries of the vapor and gas sampling events are defined by the waste surface, walls and dome of the waste tank itself. Sampling events will be scheduled to address diurnal, seasonal, and long-term changes in the vapor and gas concentrations.

* See 3.2 second paragraph for definition

Step 2. Decision Statements

A. Flammability Decision

If the total fuel content of the headspace is $\geq 20\%$ of the lower flammability limit (LFL), then work must stop until further authorization is given by management.

B. Toxicity Decision

If any compounds with toxicological properties exceed their recommended levels inside the tank headspace, then advise Health and Safety. Guideline levels are:

- 10% of the appropriate Consensus Exposure Standard (CES)* concentration for known or suspected human carcinogens, teratogens and mutagens
- 50% of the appropriate CES concentration for non-carcinogens, non-teratogens and non-mutagens, or simple irritants.

Step 3. Inputs to the Decision

- Identification and quantification of flammable constituents in the headspace
- Temperature of the headspace
- Identification and quantification of compounds of toxicological importance
- Understanding of the toxicological effects of these compounds and the CES for each constituent of concern.

Step 4. Boundaries of the Study

The spatial boundaries of the vapor and gas sampling events are defined by the waste surface, walls and dome of the waste tank itself. Sampling events will be scheduled to address diurnal, seasonal, and long-term changes in the vapor and gas concentrations.

* See 3.2 second paragraph for definition

Step 5. Decision Rules

A. Flammability Decision Rule

If the total fuel content of the headspace equals or exceeds 20% of the LFL for the observed mixture, then stop work and take appropriate actions before resuming sampling or other work on the tank.

B. Toxicity Decision Rule

The DQO team established decision rules organizing potentially toxic substances by type to include carcinogens, teratogens and mutagens, systemic toxins, and irritants. The toxicity decision rules were specified as follows:

- If the average concentration of any confirmed or suspected human carcinogen, teratogen, or mutagen in a tank headspace is greater than one-tenth of its CES, then advise the industrial hygiene group that a compound(s) of toxicological concern is present in the tank headspace so that appropriate worker protection actions can be taken.
- If the average concentration of any systemic toxin in a tank headspace is greater than one-half its CES, then advise the industrial hygiene group that a compound(s) of toxicological concern is present in the tank headspace so that appropriate worker protection actions can be taken.
- If the average concentration of any irritants in a tank headspace is greater than one-half of its CES, then advise the industrial hygiene group that a compound(s) of toxicological concern is present in the tank headspace so that appropriate worker protection actions can be taken.

Step 6. Limits on Decision Errors

A. Flammability Decision Errors

One type of decision error would occur if data incorrectly indicate $LFL_{MIX} \geq 20\%$.

A second kind of decision error would occur if data incorrectly indicate $LFL_{MIX} < 20\%$.

B. Toxicity Decision Errors

One type of decision error would occur if data incorrectly indicate that the prescribed toxicity limits have been exceeded, when in fact they haven't.

A second type of decision error would occur if data incorrectly indicate that the prescribed toxicity limits have not been exceeded, when in fact they have.

The relative consequence of the second type of decision error (failure to find a true problem) was determined to be roughly 2.5 times greater than the other type of decision error.

Step 7. Develop and Optimize the Design for Collecting Data

The Westinghouse Hanford Company (WHC) strategy to resolve the flammability and toxicity issues was approved by the U.S. Department of Energy (DOE) reviewers prior to initiation of this DQO (Gerton, O'Dell 1992). The DQO process was consequently limited by constraints imposed by these designs. Therefore, Step 7 addresses the expected performance of the flammability assessment sampling, and the proposed sampling strategy for determining headspace vapor and gas toxicity.

* * *

In conclusion, the DQO process for generic vapor sampling has been an examination of the strategy used to generate the data needed to adequately characterize the headspace of these tanks. It has proven beneficial because it has offered the stakeholders an opportunity to assess the goals and objectives of the experimental design and comment on the adequacy of the data to support their need. This re-affirmation of the "correctness" of the approach and ultimate data output enhances overall confidence in the data and ultimately in the safety decisions made from these data.

B. Toxicity Decision Errors

One type of decision error would occur if data incorrectly indicate that the prescribed toxicity limits have been exceeded, when in fact they haven't.

A second type of decision error would occur if data incorrectly indicate that the prescribed toxicity limits have not been exceeded, when in fact they have.

The relative consequence of the second type of decision error (failure to find a true problem) was determined to be roughly 2.5 times greater than the other type of decision error.

Step 7. Develop and Optimize the Design for Collecting Data

The Westinghouse Hanford Company (WHC) strategy to resolve the flammability and toxicity issues was approved by the U.S. Department of Energy (DOE) reviewers prior to initiation of this DQO (Gerton, O'Dell 1992). The DQO process was consequently limited by constraints imposed by these designs. Therefore, Step 7 addresses the expected performance of the flammability assessment sampling, and the proposed sampling strategy for determining headspace vapor and gas toxicity.

* * *

In conclusion, the DQO process for generic vapor sampling has been an examination of the strategy used to generate the data needed to adequately characterize the headspace of these tanks. It has proven beneficial because it has offered the stakeholders an opportunity to assess the goals and objectives of the experimental design and comment on the adequacy of the data to support their need. This re-affirmation of the "correctness" of the approach and ultimate data output enhances overall confidence in the data and ultimately in the safety decisions made from these data.



DATA QUALITY OBJECTIVES FOR GENERIC TANK VAPOR ISSUE RESOLUTION

1.0 INTRODUCTION

This document describes the Data Quality Objectives developed for the generic problem of tank vapor characterization. The DQO and sampling and analysis plan previously developed for the pilot tank vapor sampling effort in tank 241-C-103 (known hereafter as C-103) (Osborne 1992) were heavily relied upon for this generic vapor planning effort. The pilot DQOs and vapor sampling and analysis plan were developed prior to these generic vapor DQOs for several reasons. First, tank C-103 represents the worst case for heavy volatile organic vapors and is the greatest challenge for the development of appropriate sampling and analytical methods. Second, it has unique flammable components in its vapor headspace and has been involved in the majority of the vapor exposure incidents at Hanford. Third, a generic DQO was needed to specifically address "lesser" vapor headspace problems in other storage tanks. Fourth, there are 9 other "organic Watch List tanks" which may have similar headspace constituents but in dramatically lesser concentrations. Fifth, there are 20 FeCN class Watch List tanks which may be potential HCN producers. And lastly, 9 other tanks in BX/BY/C farms have a history of vapor incidents associated with them.

These collective 38 tanks comprise the "Suspect Tank List", which is the primary emphasis of the generic DQO. Additionally, the balance of the 177 Hanford tanks need some degree of signature characterization to determine if they meet "suspect tank criteria." The methods determined to be most successful in tank C-103 will be selected for sampling the other Suspect List tanks covered by the generic vapor DQOs contained in this document.

The DQO process starts by describing the problem. In this case, the generic problems associated with vapors in the tank farms were considered. The DQO process was used to lead the planning team through a structured set of steps that help to describe why data are needed, from where and when should data be collected, how data will be summarized and used in support of a decision, and how much uncertainty in that decision can be tolerated. The products of each step of the process are the generic DQOs. These DQOs will be considered on a tank-by-tank basis and used to develop an appropriate sampling and analysis plan designed to generate the right amount and quality of data for decision making. As better estimates of method performance and spatial and temporal variability of vapor constituents become available, the DQOs will facilitate the statistical design and analysis of all vapor data collection efforts that will take place. By specifying DQOs, an important set of criteria are documented that will enable future data users to determine data adequacy and limitations to support decision making.

The primary expectations of the DQO planning team were to build on the previous DQOs and determine the number and types of samples and analyses needed to resolve vapor safety problems for the other Suspect List tanks, and the tank farms in general. It is expected that these generic vapor DQOs will evolve and change with time. As data becomes available from the pilot project vapor sampling system (VSS) sampling event, as subsequent studies address spatial and temporal variability, and as samples are taken from other Suspect List tanks, a better set of historical data will be generated that may affect understanding of the problem and the types and number of samples needed to address the problem. Prior to each new vapor sampling event, these DQOs will be reviewed by the Vapor Program Manager, and any significant changes will be discussed with the appropriate stakeholders to ensure that whenever possible, data adequate for decision making will be generated by the vapor sampling program.

The primary expectations of the DQO planning team were to build on the previous DQOs and determine the number and types of samples and analyses needed to resolve vapor safety problems for the other Suspect List tanks, and the tank farms in general. It is expected that these generic vapor DQOs will evolve and change with time. As data becomes available from the pilot project vapor sampling system (VSS) sampling event, as subsequent studies address spatial and temporal variability, and as samples are taken from other Suspect List tanks, a better set of historical data will be generated that may affect understanding of the problem and the types and number of samples needed to address the problem. Prior to each new vapor sampling event, these DQOs will be reviewed by the Vapor Program Manager, and any significant changes will be discussed with the appropriate stakeholders to ensure that whenever possible, data adequate for decision making will be generated by the vapor sampling program.



2.0 DQO STEP 1: STATE THE PROBLEM

2.1 BACKGROUND AND SCOPE

The Tank Vapor Issue Resolution Program was established in 1992 to resolve the health and safety issues related to vapors associated with the high-level waste tanks at the Hanford Site. The issues stem from 1) an insufficient understanding of reported exposures of tank farm personnel to unacceptable levels of noxious vapors; and 2) the concern that until the vapors in the waste tanks are well characterized, the risks to worker health and safety cannot be determined.

High-level radioactive waste generated by processes at the Hanford Site has been stored since the mid-1940s in large underground storage tanks which are grouped into tank farms. Due to the variety of processes at the Hanford Site and the range of waste types stored in the tanks, the history and current inventory of each waste tank are unique.

Nineteen vapor exposure events involving 34 workers at the Hanford Site have occurred between July 1987 and May 1993. During these events, workers have reported ill effects including headaches, burning sensation in nose and throat, nausea, and impaired pulmonary function while working around waste tanks on the Hanford project. Musty and foul odors, including the smell of ammonia, have been reported to emanate from several single-shelled tanks (WHC 1994). Ten of these occurrences, involving 18 workers, were linked to C Tank Farm. In particular, tank C-103 was implicated with six of the reported occurrences.

The scope of this generic vapor characterization effort conducted under the Tank Vapor Issue Resolution Program includes two separate characterization and analytical efforts:

- 1) In-tank representative characterization or VSS^(a) and 2) In-tank signature characterization or in situ sampling (ISS).^(a)

In-tank representative characterization involves the headspace vapor sampling process that is evolving at the site, primarily from characterization efforts at tank C-103. This characterization scheme is documented in the Program Plan for the Resolution of Tank Vapor Issues (Osborne 1992). Signature characterization is a characterization program currently under development, and will benefit from the refinement of characterization design based on experience gained through the next few vapor characterization events. As additional information becomes available, the DQO will be updated and revised as needed. As such, this DQO should be viewed as a living document which will evolve with future iterations.

^(a)The vapor sample acquisition methods for these two characterization elements are described in Section 7.6.

2.2 PROBLEM STATEMENTS

2.2.1 Flammability Problem

The presence of flammable constituents in the vapors of Hanford waste tanks is a safety question that must be resolved prior to conducting any type of intrusive sampling, stabilization, or remedial activities in or around the tanks. At issue are the potential effects on the tank and the environment should a fire result from these activities. Standard WHC safety practices dictate that the flammability of the headspace of a tank must be measured and determined to be below 20% of the LFL before intrusive work may be conducted on any Watch List tank. Thirty-three of the 39 "suspect tanks" are on Watch List status.

2.2.2 Toxicity Problem

The major health issue which must be resolved is: Are compounds of toxicological significance present in the tanks at such a level that the industrial hygiene group shall be alerted to their presence so adequate breathing zone monitoring can be accomplished and future activities in and around the tanks can be performed in a safe manner.

2.2.3 Approach to Problem Resolution

The tank-by-tank approach to resolving the vapor headspace issues is to first deal with the potentially catastrophic issue of flammability. Until determinations of headspace LFL are determined, a tank cannot be characterized as having a potential flammable or non-flammable problem which will impact operational and sampling practices. Combustible gas meter readings will be taken to determine the % LFL of the headspace vapor. If these readings indicate any potential problem, samples will be taken to determine the composition and concentrations of flammable constituents in the vapor.

With resolution of the flammability issue, appropriate safe operating procedures will be established and headspace vapors will be sampled to characterize potential human health toxicity of the vapors. Dependent upon the identified vapor constituents and their concentrations, the industrial hygiene group will be advised of the presence of compounds of toxicological significance in a tank headspace. With this information in hand, the industrial hygiene group can devise health and safety procedures that will provide worker protection during subsequent sampling and operational activities. This will include personal monitoring to target compounds detected at levels of concern in the tank and to maximize the effectiveness of monitoring the worker breathing zones around the tanks.

2.3 DQO PLANNING PARTICIPANTS

Implementation of the DQO process for vapor health and safety issues involved management and technical staff spanning a wide range of disciplines, including occupational and environmental safety and health experts, engineers, chemists,

2.2 PROBLEM STATEMENTS

2.2.1 Flammability Problem

The presence of flammable constituents in the vapors of Hanford waste tanks is a safety question that must be resolved prior to conducting any type of intrusive sampling, stabilization, or remedial activities in or around the tanks. At issue are the potential effects on the tank and the environment should a fire result from these activities. Standard WHC safety practices dictate that the flammability of the headspace of a tank must be measured and determined to be below 20% of the LFL before intrusive work may be conducted on any Watch List tank. Thirty-three of the 39 "suspect tanks" are on Watch List status.

2.2.2 Toxicity Problem

The major health issue which must be resolved is: Are compounds of toxicological significance present in the tanks at such a level that the industrial hygiene group shall be alerted to their presence so adequate breathing zone monitoring can be accomplished and future activities in and around the tanks can be performed in a safe manner.

2.2.3 Approach to Problem Resolution

The tank-by-tank approach to resolving the vapor headspace issues is to first deal with the potentially catastrophic issue of flammability. Until determinations of headspace LFL are determined, a tank cannot be characterized as having a potential flammable or non-flammable problem which will impact operational and sampling practices. Combustible gas meter readings will be taken to determine the % LFL of the headspace vapor. If these readings indicate any potential problem, samples will be taken to determine the composition and concentrations of flammable constituents in the vapor.

With resolution of the flammability issue, appropriate safe operating procedures will be established and headspace vapors will be sampled to characterize potential human health toxicity of the vapors. Dependent upon the identified vapor constituents and their concentrations, the industrial hygiene group will be advised of the presence of compounds of toxicological significance in a tank headspace. With this information in hand, the industrial hygiene group can devise health and safety procedures that will provide worker protection during subsequent sampling and operational activities. This will include personal monitoring to target compounds detected at levels of concern in the tank and to maximize the effectiveness of monitoring the worker breathing zones around the tanks.

2.3 DQO PLANNING PARTICIPANTS

Implementation of the DQO process for vapor health and safety issues involved management and technical staff spanning a wide range of disciplines, including occupational and environmental safety and health experts, engineers, chemists,

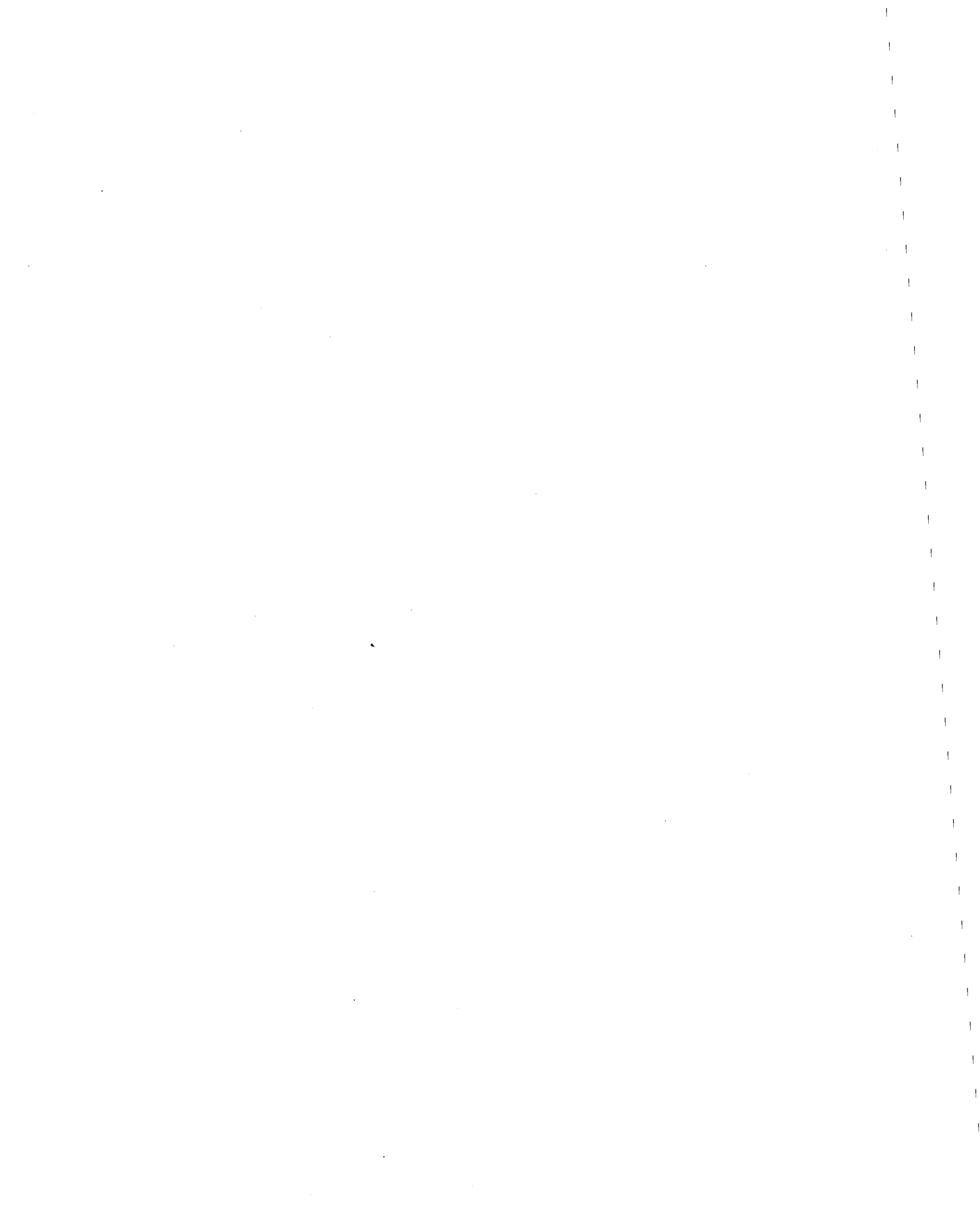

statisticians and DQO facilitators. Table 2-1 presents those personnel who participated in each of the four DQO development meetings. [Washington State Department of Ecology (WDOE) was invited to the planning meetings and received meeting notes, but was not in attendance or available for telephone conferences.] Upon completion of this document, comments will be sought by other stakeholders including DOE, USEPA and the WDOE with the goal of obtaining concurrence from all important data users. The major stakeholders have been kept informed in varying degrees about this program, prior to and during the development of these DQOs.

Table 2-1
Invited Participants in the DQO Development Effort

<u>PARTICIPANT</u>	<u>MEETING DATE</u>				<u>Stakeholder Review 02/23/94</u>
	<u>12-14-93</u>	<u>01-03-94</u>	<u>01-18-94</u>	<u>02-01-94</u>	
<u>WHC:</u>					
J. Osborne, Manager Vapor Program	x	x	x	x	x
J. Huckaby, Engineer		x		x	
T. Rudolph	x				
E. Hewitt	x		x		
P. Morant		x		x	
J. Harbinson		x			
B. Conrad					x
<u>Northwest Instrument Systems:</u>					
M. Story			x	x	x
<u>Hanford Environmental Health Foundation:</u>					
J. Calcagni					x
<u>PNL:</u>					
C. Anderson, Statistician		x	x	x	x
J. Young	x	x	x	x	
D. Mahlum, Toxicologist	x	x	x		
K. Tominey		x	x		
K. Remund, Statistician			x		
B. Pulsipher, Statistician				x	x
P. Turner, DQO Meeting Coordinator	x	x	x		
<u>Neptune and Company:</u>					
D. Michael, DQO Facilitator	x	x	x		x
R. Ryti, DQO Facilitator	x			x	
J. McCann, DQO Facilitator		x	x	x	
<u>DOE-RL:</u>					
S. Branch	x				
P. Hernandez	x				
J. Noble-Dial					x
<u>DOE-GSSC:</u>					
D. Schlick				x	x
<u>WDOE</u>					
M. Lerchen					

Table 2-1
Invited Participants in the DQO Development Effort

PARTICIPANT	MEETING DATE				Stakeholder Review 02/23/94
	12-14-93	01-03-94	01-18-94	02-01-94	
<u>WHC:</u>					
J. Osborne, Manager Vapor Program	x	x	x	x	x
J. Huckaby, Engineer		x		x	
T. Rudolph	x				
E. Hewitt	x		x		
P. Morant		x		x	
J. Harbinson		x			
B. Conrad					x
<u>Northwest Instrument Systems:</u>					
M. Story			x	x	x
<u>Hanford Environmental Health Foundation:</u>					
J. Calcagni					x
<u>PNL:</u>					
C. Anderson, Statistician		x	x	x	x
J. Young	x	x	x	x	
D. Mahlum, Toxicologist	x	x	x		
K. Tominey		x	x		
K. Remund, Statistician			x		
B. Pulsipher, Statistician				x	x
P. Turner, DQO Meeting Coordinator	x	x	x		
<u>Neptune and Company:</u>					
D. Michael, DQO Facilitator	x	x	x		x
R. Ryti, DQO Facilitator	x			x	
J. McCann, DQO Facilitator		x	x	x	
<u>DOE-RL:</u>					
S. Branch	x				
P. Hernandez	x				
J. Noble-Dial					x
<u>DOE-GSSC:</u>					
D. Schlick				x	x
<u>WDOE</u>					
M. Lerchen					

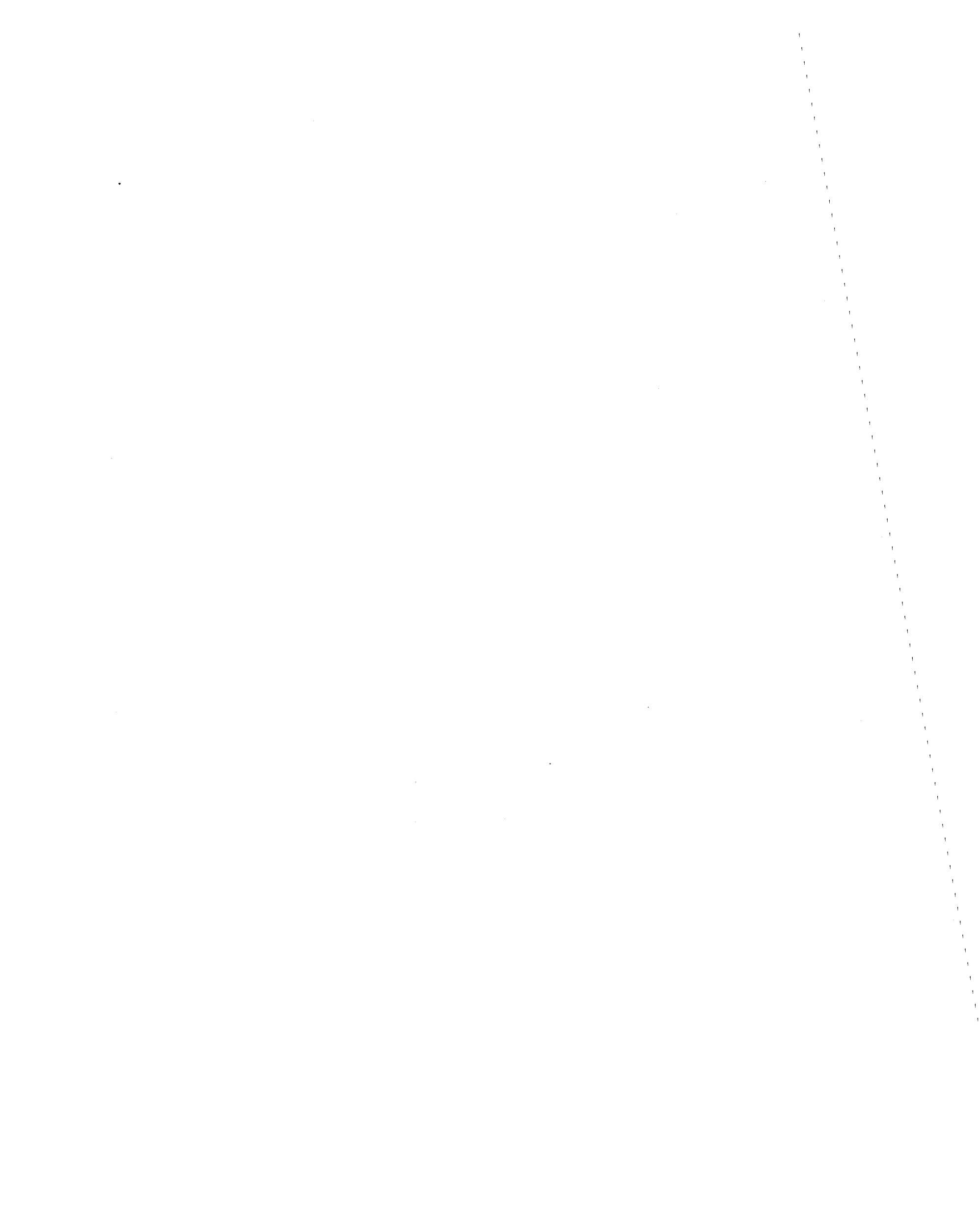

3.0 DQO STEPS 2 & 3: IDENTIFY THE DECISIONS TO BE MADE AND INPUTS TO THE DECISION

Two key decisions will be made based on the data collected--a flammability decision and a toxicity decision.

3.1 FLAMMABILITY DECISION

If the flammable gas concentration in the headspace of any tank is greater than 20% of the LFL under steady-state conditions, as measured by the combustible gas meter and/or potential sampling and analysis, then all operational and sampling activity should stop until the problem is investigated and resolved. If the flammable gas concentration in any tank is between 10 and 20% of the LFL in the headspace under steady-state conditions, then work may continue, but a sample will be collected and analyzed to determine the constituents and concentrations of the flammable constituents. If the flammable gas concentration in any tank is less than 10% of the LFL, then operational and sampling work may continue.

3.2 TOXICITY DECISION

If any compounds with toxicological properties exceed their respective trigger points inside the tank, then advise the industrial hygiene group that compounds of toxicological concern are present in the tank headspace. A trigger point is defined as:

- 50% of the appropriate CES concentration for non-carcinogens, and
- 10% of the appropriate CES concentration for carcinogens.

A CES is generally defined as the most stringent of known regulatory or recommended toxicological values for the occupational setting including the threshold limit value (TLV), permissible exposure limit (PEL), recommended exposure limit (REL), and biological exposure limit (BEI). For those constituents with unknown toxicological values, the Toxicology Review Panel (TRP) comprised of toxicologists, industrial hygienists, and occupational medicine physicians will be responsible for development of a CES.

3.3 INPUTS TO THE DECISION

3.3.1 Flammability Decision Inputs

The primary flammability data input will be via combustible gas meter readings, and in some cases, additional determination of the concentration of flammable constituents in the headspace via ISS vapor collection and targeted analysis may be required .

3.3.2 Toxicity Decision Inputs

The following data needs are associated with the toxicity decision:

- Identification of chemical compounds of worker health and safety or toxicological importance in the headspace of the tank.
- Estimates of the concentrations of these toxicologically significant compounds in the headspace.
- Understanding of the toxicological effects of these compounds and the CES for each constituent of concern.

3.3.3 Development of Consensus Exposure Standards

CESs will be generated for each compound of potential toxicological interest detected in the vapor sampling effort. Industrial hygienists have several sources of information for exposure standards against which sampling results may be compared in order to determine whether or not an unacceptable exposure condition exists. A primary source is the American Conference of Governmental Industrial Hygienists (ACGIH) recommended TLVs with some 700 chemicals listed. For compliance purposes, the PELs listed in Subpart Z of the Occupational Safety and Health Administration (OSHA) regulations are used (29 CFR 1910.1000). The National Institute of Occupational Safety and Health (NIOSH) has developed RELs based on recent research and new information about the chemicals, and these RELs are intended for adoption into OSHA regulations. The American Industrial Hygiene Association (AIHA) has also developed Workplace Environmental Exposure Level (WEEL) guides on chemicals for which no current exposure guidelines at the time have been established by other organizations.

In selecting appropriate exposure limits for the chemical constituents in the tank farm headspace vapor, the TRP will first consult the ACGIH TLVs booklet, the OSHA PEL tables, the NIOSH list of RELs, and the AIHA WEELs. The most stringent standard among the above sources will be used.

A chemical may not have published exposure standards. In this case, the TRP can provide a best estimate of the level of acceptable exposure to the chemical. This process for derivation of a consensus exposure limit must rely heavily on professional judgement of the Toxicology Review Panel at Hanford. It may involve an initial literature search in various databases for available information on the chemical. Current data bases may include:

- Registry of Toxic Effects of Chemical Substances (RTECS)
- National Air Toxics Information Clearinghouse (NATICH)
- Integrated Risk Information System (IRIS)
- Gene-Tox Database through the National Library of Medicine
- MEDLINE
- ETIC
- TOXLINE

3.3.2 Toxicity Decision Inputs

The following data needs are associated with the toxicity decision:

- Identification of chemical compounds of worker health and safety or toxicological importance in the headspace of the tank.
- Estimates of the concentrations of these toxicologically significant compounds in the headspace.
- Understanding of the toxicological effects of these compounds and the CES for each constituent of concern.

3.3.3 Development of Consensus Exposure Standards

CEs will be generated for each compound of potential toxicological interest detected in the vapor sampling effort. Industrial hygienists have several sources of information for exposure standards against which sampling results may be compared in order to determine whether or not an unacceptable exposure condition exists. A primary source is the American Conference of Governmental Industrial Hygienists (ACGIH) recommended TLVs with some 700 chemicals listed. For compliance purposes, the PELs listed in Subpart Z of the Occupational Safety and Health Administration (OSHA) regulations are used (29 CFR 1910.1000). The National Institute of Occupational Safety and Health (NIOSH) has developed RELs based on recent research and new information about the chemicals, and these RELs are intended for adoption into OSHA regulations. The American Industrial Hygiene Association (AIHA) has also developed Workplace Environmental Exposure Level (WEEL) guides on chemicals for which no current exposure guidelines at the time have been established by other organizations.

In selecting appropriate exposure limits for the chemical constituents in the tank farm headspace vapor, the TRP will first consult the ACGIH TLVs booklet, the OSHA PEL tables, the NIOSH list of RELs, and the AIHA WEELs. The most stringent standard among the above sources will be used.

A chemical may not have published exposure standards. In this case, the TRP can provide a best estimate of the level of acceptable exposure to the chemical. This process for derivation of a consensus exposure limit must rely heavily on professional judgement of the Toxicology Review Panel at Hanford. It may involve an initial literature search in various databases for available information on the chemical. Current data bases may include:

- Registry of Toxic Effects of Chemical Substances (RTECS)
- National Air Toxics Information Clearinghouse (NATICH)
- Integrated Risk Information System (IRIS)
- Gene-Tox Database through the National Library of Medicine
- MEDLINE
- ETIC
- TOXLINE



- CHEMLINE
- Monographs by the International Agency for Research on Cancer (IARC)
- Others as appropriate

Evaluation of health effects may involve a search of information about the chemical or similar analogs on adverse effects, thresholds, possible evidence of carcinogenicity, genotoxicity, developmental toxicity, reproductive toxicity, systemic toxicity, and skin/eye irritation. The no-observable-adverse-effect-level (NOAEL), if available, may be useful for animal-to-human extrapolation. Another numerical value for consideration is the maximum tolerated dose. Generally, factors considered in the toxicity evaluation of a chemical may also include its pharmacokinetic properties, effects on target organs, metabolism (biochemical reaction and transformation), and the rate of absorption and distribution. For example, when considering route-to-route extrapolation, the limitations of extrapolation are clearly apparent and one must account for:

- Difference in absorption efficiency
- Difference in systemic effects
- Occurrence of critical toxic effects at portal of entry
- First-pass effects that may result in either bioactivation or detoxification of a chemical prior to reaching the target organ
- Variations in the time course of target organ concentrations of toxicologically active species

In addition, other factors may include known specific chemical interactions, severity of effects, and other significant effects. The TRP will make various assumptions based on professional judgement to understand toxicological effects for chemicals with little or no known toxicity information. To support the tank farm vapor program, the TRP will apply methods that are scientifically defensible, short of conducting research, to formulate a recommended CES for those chemicals. Insofar as possible, the same approach that AIHA uses in establishing WEELS will be used to evaluate new chemicals.

4.0 DQO STEP 4: DEFINE STUDY BOUNDARIES

Vapor sampling will be eventually conducted on all tanks in the tank farm. This DQO differentiates between 38 of the tanks on the current "Suspect Tank List", tank C-103 (also on the "Suspect Tank List" for which DQOs were developed separately) and all other non-suspect tanks. It further differentiates between those identified as suspect tanks that are actively ventilated, and those that are not.

The spatial boundaries of both the flammability and toxicity decisions for any non-actively ventilated tanks are essentially the internal dimensions of the tank above the level of waste in the tank and not physically inside the dimensions of the riser. This volume is known as the "headspace" of the tank. Due to tank access restrictions that limit access to most of this volume, flammability and toxicity decisions for most tanks will be based on samples taken from a single location at a point approximating the midpoint of the tank volume.

Spatial boundaries for vapor decisions for actively ventilated tanks are the same; however, samples will be collected from the exhaust ventilation headers or stack rather than inside the tanks at some depth below the riser.

Concentrations of constituents in the vapor are not expected to fluctuate greatly over time, and constituents of interest in the vapor are assumed to be homogeneously distributed (well mixed) within the headspace. Accordingly, no effort to consider the time of the year for any tank will be considered. In addition, measurements of vapor constituents from anywhere within the headspace (below the risers) are expected to be representative. If and when results of C-103 samples taken over time and at three depths in the headspace refute these assumptions, the boundaries for the generic vapor DQO will be revisited and the design for sampling will consider these sources of variability.

4.0 DQO STEP 4: DEFINE STUDY BOUNDARIES

Vapor sampling will be eventually conducted on all tanks in the tank farm. This DQO differentiates between 38 of the tanks on the current "Suspect Tank List", tank C-103 (also on the "Suspect Tank List" for which DQOs were developed separately) and all other non-suspect tanks. It further differentiates between those identified as suspect tanks that are actively ventilated, and those that are not.

The spatial boundaries of both the flammability and toxicity decisions for any non-actively ventilated tanks are essentially the internal dimensions of the tank above the level of waste in the tank and not physically inside the dimensions of the riser. This volume is known as the "headspace" of the tank. Due to tank access restrictions that limit access to most of this volume, flammability and toxicity decisions for most tanks will be based on samples taken from a single location at a point approximating the midpoint of the tank volume.

Spatial boundaries for vapor decisions for actively ventilated tanks are the same; however, samples will be collected from the exhaust ventilation headers or stack rather than inside the tanks at some depth below the riser.

Concentrations of constituents in the vapor are not expected to fluctuate greatly over time, and constituents of interest in the vapor are assumed to be homogeneously distributed (well mixed) within the headspace. Accordingly, no effort to consider the time of the year for any tank will be considered. In addition, measurements of vapor constituents from anywhere within the headspace (below the risers) are expected to be representative. If and when results of C-103 samples taken over time and at three depths in the headspace refute these assumptions, the boundaries for the generic vapor DQO will be revisited and the design for sampling will consider these sources of variability.



5.0 DQO STEPS 5: DECISION RULES

The specification of decision rules for each of the identified decisions is a critical step in the DQO process. The decision rule combines the earlier statements into a single statement which specifies how data will be used to make each specified decision. Decision rules for C-103 vapor sampling were adopted for this generic vapor DQO.

5.1 FLAMMABILITY DECISION RULE

The flammability decision rules are stated below. The logic applied to the flammability decision is illustrated in Figure 1.

1. If a single sample of tank vapor fuel content, as measured below the riser with a combustible gas meter (CGM), is greater than 20% of the LFL, then the tank is potentially a flammability hazard and all operational and sampling activity shall cease until the flammability problem is investigated and resolved.
2. If a single sample of tank vapor fuel content, as measured below the riser with a CGM, is 0 to 10% of the LFL, then the tank is not considered a flammability problem and work can proceed.
3. If a single sample of tank vapor fuel content, as measured below the riser with a CGM, is greater than 10% but less than 20% of the LFL, operational and sampling activity may continue under combustible gas monitoring, and sampling will be conducted to determine the vapor constituents and concentrations of the potentially flammable mixture.

Rationale of Decision Rule

The flammability issue for waste storage tanks centers around three potential fuel sources: flammable vapors, flammable floating liquid or interstitial layers and flammable gases (e.g., H₂). This DQO process addresses only the data used to evaluate the flammability of the headspace due to combustible components (i.e., vapors and gases) which may impact the safety of operations. The flammability of a floating liquid or interstitial layer is addressed separately in the Organic USQ DQO document number PNL-8871. Industrial standards for the chemical and gas industries have been adapted for use as guidelines in the Hanford tank farm complex. An additional safety margin has been added to the standard 25% of LFL. The WHC control manual and plant operating procedure level is 20% of LFL. This level is a warning that some condition or process has changed and that some action is needed before operations are continued. The current practice is to measure the LFL and if >20%, then stop work, sample, analyze, and convene the Plant Review Committee (PRC) for review. Their options are to allow continued operation up to some predetermined higher level like 50% LFL or to require dilution or mitigation to reduce the LFL level to below 20% LFL. This logic drives the demand for highly reliable flammability data and a definitive decision rule.

5.2 TOXICITY DECISION RULE

The DQO team established decision rules organizing potentially toxic substances by type to include: the average concentration of any confirmed or suspected human (class A1 or A2) carcinogen, (also teratogens and mutagens), systemic toxins and irritants. The decision rules are specified below. The logic applied to the toxicity decision is illustrated in Figure 2.

1. If the average concentration of any confirmed or suspected human (class A1 or A2) carcinogen, teratogen, or mutagen in a tank headspace is greater than one-tenth of its CES, then advise the industrial hygiene group that a compound(s) of toxicological concern is present in the tank headspace so that appropriate worker protection actions can be taken.
2. If the average concentration of any systemic toxin in a tank headspace is greater than one-half its CES, then advise the industrial hygiene group that a compound(s) of toxicological concern is present in the tank headspace so that appropriate worker protection actions can be taken.
3. If the average concentration of any irritants in a tank headspace is greater than one-half of its CES, then advise the industrial hygiene group that compound(s) of toxicological concern are present in the tank headspace so that appropriate worker protection actions can be taken.

Rational for Decision Rule

For the average concentration of any confirmed or suspected human (class A1 or A2) carcinogens, teratogens and mutagens, a 0.1 safety factor is used in lieu of a 0.5 safety factor for irritants and systemic toxicants. These safety factors are based upon current WHC policy (WHC-CM-4-40). It should be noted that complex mixtures of compounds will be evaluated on a case-by-case basis by the Toxicology Review Panel. Grouping of like compounds and the application of mixture rules will be applied the Toxicology Review Panel to generate combined CESs for toxicity assessments.

5.3 DECISION RULE FOR SIGNATURE CHARACTERIZATION OF NON-SUSPECT LIST TANKS

If any compounds of toxicological interest are identified by the Toxicology Review Panel, then classify the problem as either organic or inorganic (e.g., NH₃, HCN), and collect a more extensive set of samples for representative characterization (see Section 7.6). In general, constituents greater than 10% of their CES will trigger this action. In addition, the Toxicity Review Panel will evaluate the potential adverse effects of complex mixtures as described above, and may request additional samples as appropriate.

**FIGURE 1
FLAMMABILITY DECISION LOGIC DIAGRAM**

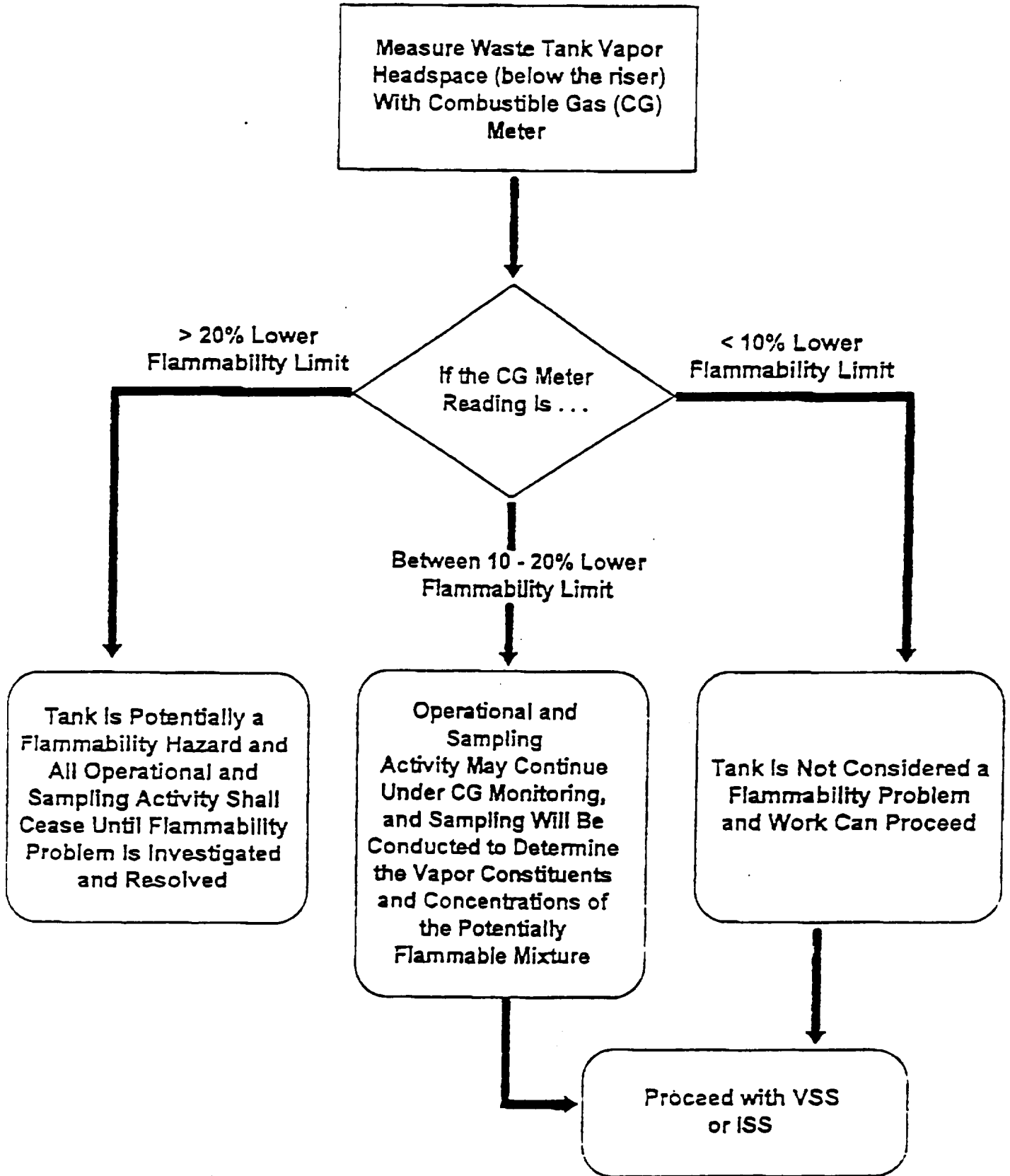
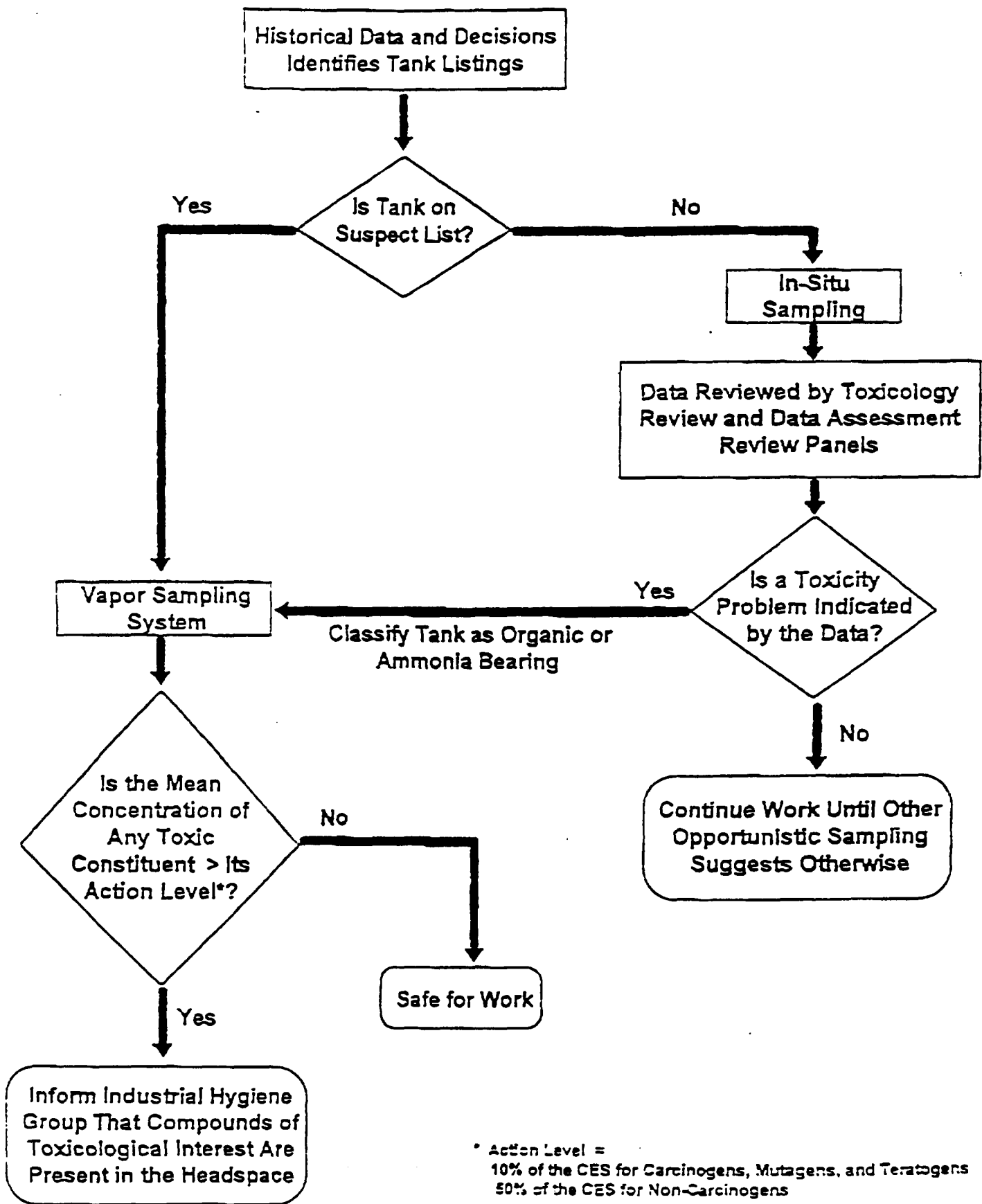

FIGURE 2 TOXICITY DECISION LOGIC DIAGRAM



* Action Level =
10% of the CES for Carcinogens, Mutagens, and Teratogens
50% of the CES for Non-Carcinogens

6.0 DQO STEP 6: LIMITS ON DECISION ERRORS

Limits on decision errors were elicited to provide a criteria against which to measure the expected performance of alternative designs. The DQO planning team decided that the decision errors and corresponding tolerances developed for the tank C-103 DQO effort should apply to the rest of the "Suspect" List tanks. No attempt to specify limits on decision errors for signature characterization events was made by the planning team.

6.1 DEVELOPMENT OF FLAMMABILITY DECISION ERROR LIMITS

The process of specifying limits on decision errors begins by identifying each type of potential decision error and discussing the consequences associated with these error types.

One type of decision error would occur if data indicate that the observed $LFL_{MIX} \geq 20\%$ (flammability is a concern), when the "true" LFL_{MIX} is $< 20\%$ (as determined by additional vapor sampling for any reason). If this occurs, work will be stopped, a safety review will be implemented unnecessarily, and a more complex analysis of LFL will be conducted. These actions would result in the following consequences:

- Increased costs
- Schedule delays
- Possible negative impact on critical path
- Credibility loss.

A second kind of decision error would occur if data indicate that the observed $LFL_{MIX} < 20\%$ (no concern with flammability), when the "true" LFL_{MIX} is $\geq 20\%$. If this occurs, then additional sampling will proceed with sampling methods that could introduce ignition sources to the headspace.

This decision error is of MAJOR CONCERN and has the following consequences:

- Potential negative safety implications
- Increased costs
- Credibility loss (when the correct....)
- Possible continued use of unacceptable operating techniques.

Desired Performance Curve Inputs

After identifying the decision errors and their associated consequences, the planning team considered a series of potential error scenarios (presumed true LFL values) and specified their aversion to these specific potential decision errors in a desired performance (Table 6-1).

Table 6-1
Desired Performance for the Flammability Decision

Presumed true fraction of the LFL	Acceptable probability of deciding to stop work
less than 0.15	≤10%
0.15 to 0.20	-
0.20 to 0.50	≥90%
more than 0.50	≥99%

6.2 DEVELOPMENT OF TOXICITY DECISION ERROR LIMITS

One type of decision error would occur if we observe that the action level (10% of the CES for carcinogens, and 50% of the CES for systemic toxicants and irritants) has been exceeded, when, in fact, the "true action level" has not been exceeded. If this decision error occurs, then worker protection control measures and breathing zone monitoring requirements will be over-prescribed, resulting in the following consequences:

- Increased costs
- Injury or illness to workers resulting from the wearing of personal protection equipment
- Credibility loss
- Scheduled delays.

A second type of decision error would occur if we observe that the action level (10% of the CES for carcinogens, and 50% of the CES for systemic toxicants and irritants) has not been exceeded, when in fact the "true action level" has been exceeded. If this decision error occurs, then workers could potentially be exposed to toxic vapors. This decision error is of major concern and would result in the following consequences:

- Potential worker illness
- Credibility loss
- Increased costs
- Liability to WHC/DOE.

Desired Performance Curve Inputs

Three different sets of constituents were considered independently due to the types of consequences and differences in action levels. Tables 6-2, 6-3, and 6-4 depict the decision error limits established during the DQO development exercise. Since the consequences were most severe for carcinogens, the error tolerances were tightest for these constituents. In all likelihood, these constraints will drive the sampling and analysis design. In fact, the analytical experts predicted that a design adequate to determine if benzene exceeded its CES would be more than adequate to make decisions for all other constituents of concern.

Table 6-2
 Desired Performance for the Toxicity Decision:
 Average Concentration of Confirmed/Suspected Human (Class A1/A2)
 Carcinogenic, Teratogenic or Mutagenic Constituents

Presumed "true" fraction of the CES	Acceptable probability of deciding toxic constituents are present
less than 0.01	≤1%
0.01 to 0.05	≤20%
0.05 to 0.1	-
0.1 to 0.5	≥80%
0.5 to 1	≥95%
1 or more	≥99%

Table 6-3
 Desired Performance for the Toxicity Decision:
 Systemic Toxicant Constituents

Presumed "true" fraction of the CES	Acceptable probability of deciding toxic constituents are present
less than 0.05	≤1%
0.05 to 0.25	≤25%
0.25 to 0.5	-
0.5 to 1	≥95%
more than 1	≥99%

Table 6-4
 Desired Performance for the Toxicity Decision: Irritant Constituents

Presumed "true" fraction of the CES	Acceptable probability of deciding toxic constituents are present
less than 0.05	≤1%
0.05 to 0.25	≤25%
0.25 to 0.5	-
0.5 to 1	≥95%
1 or more	≥99%

7.0 SAMPLING AND ANALYSIS DESIGNS FOR OBTAINING DATA

7.1 STATISTICAL TERMINOLOGY

The performance tables in Section 6 provide a tool for the decision makers to describe the acceptable probability of making a decision error. The theory behind these tables is based on statistical hypothesis testing, in which the data are used to decide between one condition of the environment (the null hypothesis, H_0) and an alternative condition (the alternative hypothesis, H_A). The null hypothesis is assumed to be true in the absence of strong evidence to the contrary. A decision error occurs when the decision makers are led to believe in one hypothesis when the other is true.

There are two types of decision errors that must be considered. The first type of decision error occurs when the decision makers conclude, based on the data, that H_A is true when, in fact, H_0 is true. This error is sometimes referred to as a false positive, or a Type I, error. When the decision makers specify how often they can tolerate making this type of decision error (e.g. 5 out of 100 times), that is often referred to as the Type I error rate, or α . The second error occurs when the decision makers conclude, based on available data, that H_0 is true when, in fact, H_A is true. This error is sometimes referred to as false negative, or Type II, error. The Type II error rate, or β , is the specification of how often the decision maker can tolerate making this type of decision error.

7.2 DESIGN ASSUMPTIONS

For each vapor sampling event, the flammability and toxicity decision rule will both be addressed. The two assumptions of importance are that the headspace is anticipated to be relatively homogeneous, and that the total study error is approximately equal to measurement error.

7.3 SELECT THE APPROPRIATE STATISTICAL TEST

The hypotheses and statistical tests developed for C-103 heated tube flammability determinations are applicable for generic vapor flammability determinations that are based on the analysis of flammable constituents. For most tanks, the expected value of the CMG is expected to be well below 10% of the LFL. In these cases, a direct comparison of the measured value to 10% of the LFL will be used; hence no statistical test will be conducted.

The hypotheses for the toxicity decision rule for carcinogens are distinguished by a comparison of the average concentrations of confirmed or suspected human (class A1 or A2), carcinogens (this includes teratogens and mutagens) to their corresponding action level (0.1 times the CES for carcinogens). The goal of the testing procedure is to determine if there is sufficient evidence in the collected data to reject the hypothesis that the average concentration of carcinogens is greater than the action level. The

appropriate classical statistical test for resolving this problem is a one sided t-test. The hypotheses can be stated as follows:

H_0 : Mean concentration of each carcinogen ≥ 0.1 times CES

H_A : Mean concentration of each carcinogen < 0.1 times CES.

The desired performance (Table 6-2) indicates that the specified probability of deciding toxic constituents are present at the hypothesis boundary of 0.1 times CES is 0.80. Since this corresponds to making the correct decision when the null hypothesis is true, the probability of making an incorrect decision when the null hypothesis is true (i.e., the probability of deciding H_A when in fact H_0 is true) is one minus 0.80, or 0.20. Thus, the Type I error rate, or α , is 0.20 (i.e., the probability of deciding that toxic constituents are not present when, in fact, they are, is no greater than 0.20). Also indicated is that the probability of deciding to stop work at 0.05 times the CES should be \leq to 0.20. Since this corresponds to making an incorrect decision when the alternative hypothesis is true, the Type II error rate at 0.05 times CES, or β at 0.05 times CES, is 0.20 (i.e., the probability of deciding that the toxic constituents are present when, in fact, they are not, is no greater than 0.20). The region of decision indifference is defined in the desired performance curve at 0.05 to 0.10 times CES.

The hypotheses for the toxicity decision rule for systemic toxins and for irritants are distinguished by a comparison of the average concentrations of systemic toxins or irritants to the action level of 0.5 times its CES. The appropriate classical statistical test for resolving these problems is a one sided t-test. The hypotheses can be stated as follows:

H_0 : Mean concentration of each systemic toxin $\geq 0.50 \times$ CES

H_A : Mean concentration of each systemic toxin $< 0.50 \times$ CES

and

H_0 : Mean concentration of each irritant $\geq 0.50 \times$ CES

H_A : Mean concentration of each irritant $< 0.50 \times$ CES.

The desired performance curves for these decisions are found in Tables 6-3 and 6-4. Using the same discussion as for carcinogens, the Type I error rate, or α , for these constituents is 0.05. The Type II error rate at 0.25 times CES, is 0.25. The region of decision indifference is between 0.25 and 0.5 times CES.

7.4 OBTAIN PERTINENT ESTIMATES OF UNCERTAINTY

No estimates of uncertainty were available for the measurement error for the FC_{Mixture} . As data appropriate for obtaining pertinent estimates of uncertainty become available from C-103, statistical sampling designs will be

considered for other Suspect List tanks. Until that time, professional engineering based designs will be used to obtain samples for decision making.

Estimates of uncertainty for the toxicity decision rule also do not exist at this time. Engineering judgement estimates of the important sources of uncertainty could be obtained, but none of the estimates can be directly tied to observed data.

7.5 POWER ANALYSIS

No power analyses were performed for either the flammability or toxicity decision rules because no prior estimates of uncertainty were available. A retrospective power analysis could provide a useful look at the achievable probabilities of decision error as estimates of uncertainty become available.

7.6 VAPOR SAMPLE ACQUISITION METHODS

Two methods will be used to collect gas and vapor samples for the waste tanks. The primary method employs heated transfer tubing, a heated sampling manifold, relatively sophisticated temperature, flow control, and valving technology, and a vacuum pump to draw air, gases, and vapors out of the waste tanks. Different types of samples can be taken from several stations of the manifold, which is housed with the measurement and control equipment in a climate-controlled mobile laboratory. This method currently requires that a special vapor sampling probe be installed by crane into a riser of the tank. The integrated equipment (e.g., probe, heated transfer tubing, and everything in the mobile laboratory) is referred to as the Vapor Sampling System or VSS.

The VSS was specifically designed to collect representative samples from warm, moist tanks, even if there is a fog in the headspace. Advantages of the VSS include the abilities to perform sampling in adverse weather conditions, to house real-time analytical equipment, and to address high concentrations of organic vapors. Problems yet to be fully addressed include the potential adsorption and loss of certain species on the walls of the transfer lines, and the limitations of a single system to meet the desired sampling schedule.

The second method for collecting gas and vapor samples from the waste tanks is referred to as ISS. Rather than transferring the air, gases, and vapors to be sampled to a remote location, the sampling devices themselves (specifically sorbent traps) are lowered down into the headspace of the tank. This assures representative samples and avoids problems associated with the loss of analytes via wall adsorption.

The ISS method uses simple, inexpensive flow monitoring and control equipment, which currently is mounted on a 2-wheel hand cart. The required equipment is easy to maintain and duplicate. The ISS method provides the ability to collect samples quickly and without the special sampling probe of the VSS. Disadvantages of the ISS method include current limitations on its ability to sample some volatile organic vapors under certain conditions (e.g., acetone in a high-humidity tank) and that each sampling event involves breaking the

containment of the tank. The shipment and analysis of ISS sorbent traps is also currently dependent on proving no radiolytic contamination of the traps has occurred.

A limited ISS event that addresses the most significant noxious gases and vapors, requiring less than 1 hour at an open tank riser, is planned for each single-shell waste tank scheduled for intrusive work, on an opportunistic basis. The opportunistic use of the ISS method is being designed to maximize information obtained while minimizing sampling costs and time. These sampling events are currently designed to collect triplicate sorbent trap samples of ammonia, nitrogen dioxide, nitrogen monoxide, and water vapor. Additionally, triplicate SUMMA canister samples will be collected from the same vicinity as the other samples via an unheated tube, and will be analyzed for volatile organic vapors. Potential radiolytic contamination of the sorbent traps will be addressed by simultaneously collecting a OVS trap for sacrificial radiolytic analysis. The ISS method will also be used to examine several waste tanks for the presence of hydrogen cyanide gas, in support of the Ferrocyanide Tank Safety Program.

7.7 ADAPTIVE ANALYSIS STRATEGY

For the generic tank vapor analysis, the following adaptive analysis strategy will be employed.

If a pre-existing flammable safety concern is relevant, a flammability meter reading and/or an in situ sorbent sampling using OSHA Versatile Sampling and analysis technology as described in "Aerosol and Vapor Characterization of Tank 241-C-103" (PNL-8875/UC-606) or equivalent will be employed for resolution.

If not, a representative sample of the tank headspace will be taken in a manner that has been shown to be effective to address any documented concerns and the DQOs for that tank, (SUMMA canisters, sorbent tubes, impingers). Standard, accepted, ambient air analysis methodologies such as chemical class detectors (hydrocarbon, halogen, etc.), gas chromatography, mass spectrometry, ion chromatography or colorimetry will be employed to determine concentrations above 1 part per billion (volume). The analysis will specify by chemical the concentration detected and the confidence of that measurement. Historically achieved performance can be substituted for non-standard gases. If the list of identified gases contains any analytes that are of concern to the program; e.g., toxicity, those concerns will be judged with respect to the data and a determination made as to the adequacy of the sampling and analysis or whether additional work needs to be done. This may mean the convening of an expert panel, operational controls or other resolution means that are cost effective.

This methodology is being employed with respect to tank C-103, and the anticipated dates for accomplishment are:

Representative sampling	January 27, 1994
List of analytes present	February 23, 1994
Identification of analytes of concern	March 1, 1994
Selection of analytical method(s)	March 9, 1994
Modification of methods	June 30, 1994
Quantitative analysis to a known certainty	June 30, 1994

8.0 REFERENCES

- Gerton, R.E., C. O'Dell, 1992, *Review of the "Westinghouse Plan for Controlling and Dealing with Noxious Gases in the Tank Farms at Hanford"*, (letter to the President, November 27), U.S. Department of Energy, Richland Field Office, Richland, Washington.
- Michael, D.I., D. Neptune, R. Ryti, P. Black, J. Scott, B. Pulsipher, 1993, *Tank Waste Remediation System Data Quality Objectives Process Guidance: Requirements, Style and Content*, Draft Guidance.
- Osborne, J.W., 1992, *Program Plan for the Resolution of Tank Vapor Issues*, WHC-EP-0562, Westinghouse Hanford Company, Richland, Washington.
- Turner, D.T., *Organic Layer Sampling for SST 241-C-103 Background, and Data Quality Objectives, and Analytical Plan*, PNL-8871, Pacific Northwest Laboratory, Richland, Washington.
- USEPA, 1993, *Guidance for Planning Data Collection in Support of Environmental Decision Making Using the Data Quality Objectives Process*, EPA QA/G4, Interim Final, U.S. Environmental Protection Agency, Washington, D.C.
- WHC, 1994, *Tank 241-C-103 Vapor and Gas Sampling Data Quality Objectives*, WHC-EP-0774, Westinghouse Hanford Company, Richland, Washington.

ATTACHMENT A

Data Quality Objectives for Tank Hazardous Vapor Safety Screening

Consisting of 43 Pages Including Introduction

INTRODUCTION:

Any strategy describing the overall approach to safe storage and disposal of waste must identify the problems and decisions requiring characterization data. Requirements for obtaining tank characterization information are developed through the use of the Data Quality Objectives (DQO) process. The DQO process addresses each decision or group of related decisions to specify data needs.

The initial attempt at performing the DQO process to address safety issues revealed points where significant assumptions would be required to proceed. Although the problems and decisions were identified, details of the error tolerances and confidence levels were difficult to develop. Attempts to optimize the data collection for each tank were affected by the limited locations from which samples could be obtained and concerns that samples did not represent overall waste contents. The complexity of sampling made it impossible to design a high confidence data acquisition scheme based solely on multiple samples, and necessitated review of the overall strategy for obtaining data and resolving issues.

A revised safety strategy for the storage of tank waste was developed, focused on ensuring safe operations over a range of waste material rather than on characterizing waste in great detail. The revised safety strategy includes several assumptions about the nature of the waste which require verification through additional sample analysis. Should these assumptions be shown to be well founded, the approach to screening the waste for safety issues and resolving those issues is considerably simplified. The following draft of the data requirements, based on the revised safety strategy, has been prepared.

Clearly any assumptions must be addressed before proceeding with the revised safety strategy. The preceding minor revisions to the baseline DQO document were found to be adequate to perform safety analyses in the near term, while specific additional information needs are pursued to verify the assumptions in the revised safety strategy. In addition to resolving the assumptions, the near term sampling events will obtain information which will support the determination of error tolerances, confidence levels, and optimization schemes in the finalized version of the revised safety strategy DQO. The approach taken in the revised baseline DQO document, simply requesting multiple samples per tank, is the appropriate first step to finalizing the optimization requirements.

The DQO process is iterative in nature. It is anticipated that the data collected in the near term, based on the revised baseline DQO document, will provide the added information needed to provide complete DQO requirements for longer term characterization. As such, the following revised safety strategy DQO may continue to undergo further development and revision as this added information becomes available. At the appropriate time after the revised safety strategy DQO is completed, the necessary reviews and approvals will be conducted and the document will become the new baseline.

WHC-SD-WM-DQO-002, Rev. 1

DATA QUALITY OBJECTIVES FOR TANK HAZARDOUS VAPOR SAFETY SCREENING

J. W. Osborne

April 1995

The author wishes to acknowledge participation of the following organizations, agencies, and individuals in the Data Quality Objectives process to address hazardous vapor screening. They are: Jim Huckaby (Pacific Northwest Laboratory), Roger Mitchell, David Carls, Elton Hewitt (Westinghouse Hanford Company, Industrial Health & Safety). The Vapor Conference Committee, specifically Harry Babad (Westinghouse Hanford Company), Amy Dindal (Oak Ridge National Laboratory), Tom Gardner-Clayson (U.S. Army Corps of Engineers, Walla Walla District), Steve Goheen (Pacific Northwest Laboratory), Roger Jenkins (Oak Ridge National Laboratory), Bruce Kowalski (University of Washington), William Lonneman (U.S. Environmental Protection Agency, Research Triangle Park), Rampur Viswanath (Westinghouse Hanford Company), Margil Wadley (U.S. Environmental Protection Agency, California Air Board) Alex Stone (State of Washington Department of Ecology), Region 10 (U.S. Environmental Protection Agency). At U.S. Department of Energy, Richland Operations Office the author wishes to acknowledge the review of the working draft by Ted Noble, Paul Hernandez, Jim Thompson, Mary Jarvis, Stan Branch, and at Mac Technical Services Company, Sam Murff, Joe Haney, and Greg Joyce.

DATA QUALITY OBJECTIVES FOR TANK HAZARDOUS VAPOR SAFETY SCREENING

EXECUTIVE SUMMARY

Data Quality Objectives (DQOs) for hazardous vapors were developed using the most recent U.S. Environmental Protection Agency (USEPA) DQO guidelines (EPA QA/G-4, September 1994). Within the general framework of hazardous vapor consideration, two specific vapor problem areas: flammability and toxicity, are addressed. Although these areas are addressed generally in the Safety Screening DQO, more detail is contained in the specific Flammable Gas DQO and contained here in the Tank Hazardous Vapor Safety Screening DQO. What follows is a summary of the outputs of the DQO process for hazardous vapor screening as prescribed by the stakeholders (U.S. Department of Energy [DOE), State of Washington Department of Ecology (Ecology), USEPA, and internal Westinghouse Hanford Company (WHC) customers for vapor data). More details regarding the rationale for each of the DQO planning outputs are contained in the DQO document that follows this executive summary (refer to Figure 1-1 for master DQO logic).

Step 1. Problem Statement

Two potential problems affecting the safe storage of high level radioactive waste at the Hanford Site are: 1) are potential flammable levels of gases and vapors generated or released in waste storage tanks headspace above the 25% LFL level and, 2) is there potential for worker hazards associated with the toxicity of constituents in any fugitive vapor emissions from these tanks? The fuel content of the tank gases and vapors may be too high to permit safe work or continued safe waste storage in or near these tanks. Changes to certain key sentinel gases or vapors in the tank headspace may indicate precursor exothermic reactions. Therefore, it is necessary to baseline the headspace signature before delta changes can be detected. Numerous reports of adverse health effects associated with vapor exposures in and around tank farms have been made by workers. Confirmed symptoms from these exposure incidents include headaches, burning sensations in nose and throat, nausea, and impaired pulmonary function.

Data are needed to identify and quantify constituents of the tank headspaces as source terms to address potential vapor toxicity and safe storage headspace characterization. If any compounds of toxicological interest are identified in the tank headspace, industrial hygienists can use this information to assess "worst-case" worker exposure levels and focus their industrial hygiene air monitoring strategy on these target compounds. Final recommendations on the required level of personal protective equipment will be based on the worker breathing zone levels of these chemicals. The ultimate goal is to provide safe storage and a healthful workplace in the tank farms complex.

Generation of the required data for resolution of these problems involves a sequence of sampling events. The first sampling event assesses flammability of the volatile organic vapor, ammonia, methane, and other flammable gases present in the tank headspace. If the flammability assessment results are

1V
A-5

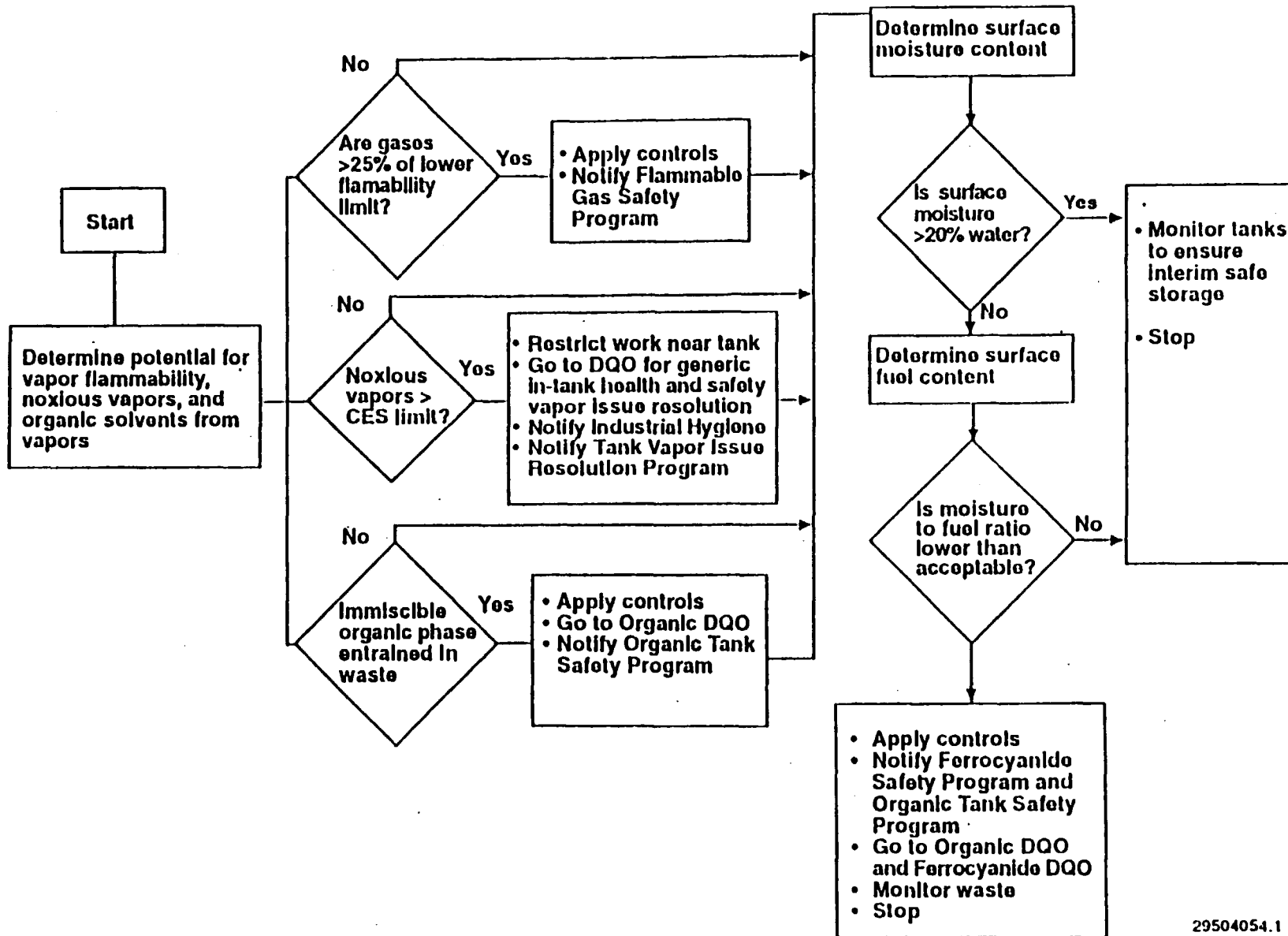

Figure 1-1. Logic Diagram for Safety Screening DQO Process.

acceptable (< 25% LFL) then special in situ sorbent tube bundles can be lowered into the tank. This equipment will be used in subsequent sampling evolutions to: 1) establish concentrations of all flammable headspace constituents; 2) identify compounds of toxicological concern; and 3) quantify compounds of toxicological concern.

Ultimately these data will be used to complete the TPA Milestone M-44 required characterization of the tanks, provide information to guide industrial hygiene air monitoring, provide a design baseline for future or upgraded vapor treatment systems and to provide source term information for estimating fugative air emission inventories.

Step 2. Decision Statements

A. Flammability Decision

If the total fuel content of the headspace is $\geq 25\%$ of the lower flammability limit (LFL), then work must stop until further authorization is given by management. The Plant Review Committee may request additional safety screening to identify the fuel constituents in the tank headspace. This can be accomplished by extended analysis of vapor samples collected and held in reserve from the initial vapor sampling event. This eliminates the need to revisit and resample a tank.

B. Toxicity Decision

If any compounds are detected by the chosen sampling and analytical methods with toxicological properties exceeding their recommended levels inside the tank headspace, then Industrial Health and Safety (IH&S) can make further determinations if additional personal monitoring samples need to be taken to document real exposure situations and assess the adequacy of engineering controls and personal protective equipment. The guideline levels are: at 100% of the appropriate Consensus Exposure Standard (CES)* concentration for all detectable chemicals or .1 ppm which ever is lower.

The principal decision to be made during analysis is the compounds and levels that will be looked for during the analytical procedure. The toxicity decision should be to look for all chemicals detectable by the sampling and analytical methods used that are present above the lower of their CES or 0.1 ppm. Because of the methods used, the data generated for tentatively identified compounds in only semi-quantitative. However, based on the compound specified above, a level of +/- 50% should be sufficient. Thus, and compound which is estimated to be present at or above 0.1 ppm or the CES for this chemical should be reported to Industrial Health and Safety.

Step 3. Inputs to the Decision

- Initial measurement of tank headspace flammability (CGM based and expressed as % LFL).

*See 3.2 second paragraph for definition

- Identification and quantification of flammable constituents in the headspace (OVM based for TOC concentration and GC/MS based for identification of fuel components).
- Temperature of the headspace and waste.
- Humidity of vapor headspace.
- Identification and quantification of compounds of toxicological importance (GC/MS/IR based data from extended analysis LD > 100 ppb).
- Understanding of the toxicological effects of these compounds and the CES for each constituent of concern (tank vapor database).

Step 4. Boundaries of the Study

The spatial boundaries of the vapor and gas sampling events are defined by the waste surface, walls and dome of the waste tank itself. The tank headspace is assumed to be well mixed based upon convective mixing modeling (Wood and Claybrook) and actual experimental measurement in extended studies of tank 241-C-103. Until further special studies of other single-shell tanks is accomplished, this supposition is considered an assumption based upon modeling and a single tank data set. Vapor sampling from a single point near the centroid of the headspace volume is desirable. Sampling events will be completed in fiscal year 1996 to address diurnal, seasonal, and long-term changes in the vapor and gas concentrations. After the tank's headspace vapor concentration is baselined, periodic monitoring of the tank will be required to identify any delta changes. This information used in conjunction with waste temperature, waste near-surface moisture, and headspace moisture content can provide early warning of changes in tank conditions which might affect continued safe storage.

Step 5. Decision Rules

A. Flammability Decision Rule

If the total fuel content of the headspace equals or exceeds 25% of the LFL for the observed mixture as a instantaneous reading, then stop work and take appropriate actions before resuming sampling or other work on the tank.

B. Toxicity Decision Rule

The toxicity decision rules were specified as follows:

If the average concentration of any detected systemic toxin in a tank headspace is greater than 100% of its CES, or .1 ppm, then advise the industrial hygiene group that a compound(s) of toxicological concern is present in the tank headspace so that appropriate worker protection actions can be assessed.

Step 6. Limits on Decision Errors

A. Flammability Decision Errors

One type of decision error would occur if data incorrectly indicate $LFL^{MIX} < 25\%$

A second kind of decision error would occur if data incorrectly indicate - $LFL^{MIX} < 25\%$

Because the 25% LFL level is an advisory level, it cannot be treated as a absolute action or trigger level.

B. Toxicity Decision Errors

One type of decision error would occur if data incorrectly indicate that the prescribed toxicity limits have been exceeded, when in fact they haven't.

A second type of decision error would occur if data incorrectly indicate that the prescribed toxicity limits have not been exceeded, when in fact they have.

A third type of error may result if the sampling and analytical methods used do not detect all chemicals present in the headspace.

The relative consequence of the second type of decision error (failure to find a true problem) was determined to be roughly 2.5 times greater than the other type of decision error.

Step 7. Develop and Optimize the Design for Collecting Data

The Westinghouse Hanford Company (WHC) strategy to resolve the flammability and toxicity issues was approved by the U.S. Department of Energy (DOE) reviewers prior to initiation of this DQO (Gerton, O'Dell 1992). The DQO process was consequently limited by constraints imposed by these designs. Therefore, Step 7 addresses the expected performance of the flammability assessment sampling, and the proposed sampling strategy for determining headspace vapor and gas toxicity.

The specific experimental approach, vapor collection methods, equipment and sampling package configuration, number of samples and type collected and specific analytical procedures are called out in the tank specific Tank Characterization Plan (TCP). The sampling matrix contained in each TCP additionally addresses precision, accuracy, limit of detection and notification limits.

* * *

In conclusion, the DQO process for hazardous vapor sampling has been an examination of the strategy used to generate the data needed to adequately screen and characterize the headspace of these tanks for the purpose of assessing the safe storage conditions of the waste. This process has proven beneficial because it offers the stakeholders an opportunity to assess the goals and objectives of the experimental design and comment on the adequacy of the data to support their need. This re-affirmation of the "correctness" of

the approach and ultimate data output enhances overall confidence in the data and ultimately in the safety decisions made from these data.

TABLE OF CONTENTS

1.0	INTRODUCTION	1
2.0	DQO STEP 1: STATE THE PROBLEM	5
2.1	BACKGROUND AND SCOPE	5
2.2	PROBLEM STATEMENTS	6
2.2.1	Flammability Problem	6
2.2.2	Toxicity Problem	6
2.2.3	Approach to Problem Resolution	6
3.0	DQO STEPS 2 & 3: IDENTIFY THE DECISIONS TO BE MADE AND INPUTS TO THE DECISION	10
3.1	FLAMMABILITY DECISION	10
3.2	TOXICITY DECISION	10
3.3	INPUTS TO THE DECISION	10
3.3.1	Flammability Decision Inputs	12
3.3.2	Toxicity Decision Inputs	12
3.3.3	Development of Consensus Exposure Standards	12
4.0	DQO STEP 4: DEFINE STUDY BOUNDARIES	14
5.0	DQO STEPS 5: DECISION RULES	15
5.1	FLAMMABILITY DECISION RULE	15
5.2	TOXICITY DECISION RULE	16
6.0	DQO STEP 6: LIMITS ON DECISION ERRORS	18
6.1	DEVELOPMENT OF FLAMMABILITY DECISION ERROR LIMITS	18
6.2	DEVELOPMENT OF TOXICITY DECISION ERROR LIMITS	19
7.0	SAMPLING AND ANALYSIS DESIGNS FOR OBTAINING DATA	22
7.1	STATISTICAL TERMINOLOGY	22
7.2	DESIGN ASSUMPTIONS	22
7.3	SELECT THE APPROPRIATE STATISTICAL TEST	22
7.4	OBTAIN PERTINENT ESTIMATES OF UNCERTAINTY	23
7.5	POWER ANALYSIS	24
7.6	VAPOR SAMPLE ACQUISITION METHODS	24
7.7	ADAPTIVE ANALYSIS STRATEGY	27
8.0	REFERENCES	32

LIST OF TABLES

Table 2-1.	Target Analytes of Toxicological Interest	8
Table 3-1.	Summary of Decision Inputs.	11
Table 5-1.	Decision Rule.	17
Table 6-1.	Desired Performance for the Flammability Decision	19
Table 6-2.	Desired Performance for the Toxicity Decision: Average Concentration of Confirmed/Suspected Human (Class A1/A2) Carcinogenic, Teratogenic or Mutagenic Constituents	20
Table 6-3.	Desired Performance for the Toxicity Decision: Systemic Toxicant Constituents	20
Table 6-4.	Desired Performance for the Toxicity Decision: Irritant Constituents	21
Table 7-1.	Sample Chemical, Physical, And Radiological Analytical Requirements	31

LIST OF FIGURES

Figure 1-1.	Logic Diagram for Safety Screening DQO Process.	iv
Figure 1-2.	Overview of Waste Tank Safety Issue Resolution Logic (1 of 2)	2
Figure 1-3.	Overview of Waste Tank Safety Issue Resolution Logic (2 of 2)	3
Figure 7-1.	Vapor Sampling System	25
Figure 7-2.	In Situ Vapor System	26
Figure 7-3.	Comprehensive Hazardous Vapor Safety Screening Program . . .	28

LIST OF ACRONYMS

ACGIH	American Conference of Governmental Industrial Hygienists
AIHA	American Industrial Hygiene Association
CES	Consensus Exposure Standard
CGM	Combustible Gas Meter
DOE	U.S. Department of Energy
DOE-RL	U.S. Department of Energy - Richland Operations Office
DQO	Data Quality Objectives
ISVS	In Situ Vapor System
LFL	Lower Flammability Limit
NIOSH	National Institute of Occupational Safety and Health
OSHA	Occupational Safety and Health Administration
OVN	Organic Vapor Monitor
OVS	OSHA Versatile Sampler
PEL	Permissible Exposure Limit
REL	Recommended Exposure Limit
SUMMA®	Registered Trademark for Passivated Stainless Steel Canister
TLV	Threshold Limit Value
USEPA	U. S. Environmental Protection Agency
VRP	Vapor Review Committee
VSS	Vapor Sampling System
WEEL	Workplace Environmental Exposure Level
WHC	Westinghouse Hanford Company
ECOLOGY	State of Washington Department of Ecology

DATA QUALITY OBJECTIVES FOR TANK HAZARDOUS VAPOR SAFETY SCREENING

1.0 INTRODUCTION

This document describes the Data Quality Objectives developed for the screening of the hazardous tank headspace vapors. Tank 241-C-103 and the other Watch List tanks represent the "worst" challenge for heavy volatile organic and ammonia vapor characterization. There are 18 FeCN class Watch List tanks, 19 organic Watch List tanks, and 14 other tanks in BX/BY/C farms which have a history of vapor incidents associated with them. These collective 43 tanks comprise the Suspect Tank List.

Two classes of chemicals (organics and ammonia) are the principal drivers for the development of appropriate sampling and organic/inorganic analytical methods. A screening DQO was needed to specifically address "lesser" vapor headspace problems in other storage tanks and to focus on non-organic sentinel gases like NH_3 and N_2O , CO_2 , CO and N_2O . For instance, there are now four other "organic tanks" which may have similar headspace constituents to organic Watch List tanks but in dramatically lesser concentrations. These organic signatures and their long-term stability may be important sentinels for tank safety.

The group of tanks covered by this DQO are the remaining unsampled passively ventilated single-shell tanks. Safe storage screening and characterization of these "lesser tanks" to some degree is needed to determine if they meet or exceed safety screening criteria and to properly categorize them for health and safety reasons (i.e., primary NH_3 tank). The methods developed for the characterization of Suspect List tanks will be used to screen (i.e., EPA TO-12) and fully characterize (i.e., EPA TO-14) these tanks as needed.

The DQO process starts by describing the problem. In this case, the two problems associated with vapors in the tank farms were considered. The DQO process was used to lead the DQO team through a structured set of steps that help to justify why data are needed, from where and when should data be collected, how data will be summarized and used in support of a decision, and how much uncertainty in that decision can be tolerated in relation to overall tank safety risk assessment. The products of each step of the process constitute the hazardous safety screening DQO. This DQO will be considered on a generic tank basis and used to develop an appropriate tank specific Tank Sampling Plan designed to generate the right amount and quality of data for decision making on that particular tank (see detailed logic in Figure 1-2 and Figure 1-3). As better estimates of method performance and spatial and temporary variability of vapor constituents become available, the DQO will be the vehicle to revisit the statistical design and modify the analytical approach and sampling methods of all vapor data collection efforts that will take place in the future. By specifying a DQO, an important set of criteria are established that will enable a technical review group to determine data adequacy and limitations to support decision making.

Figure 1-2. Overview of Waste Tank Safety Issue Resolution Logic. (1 of 2)

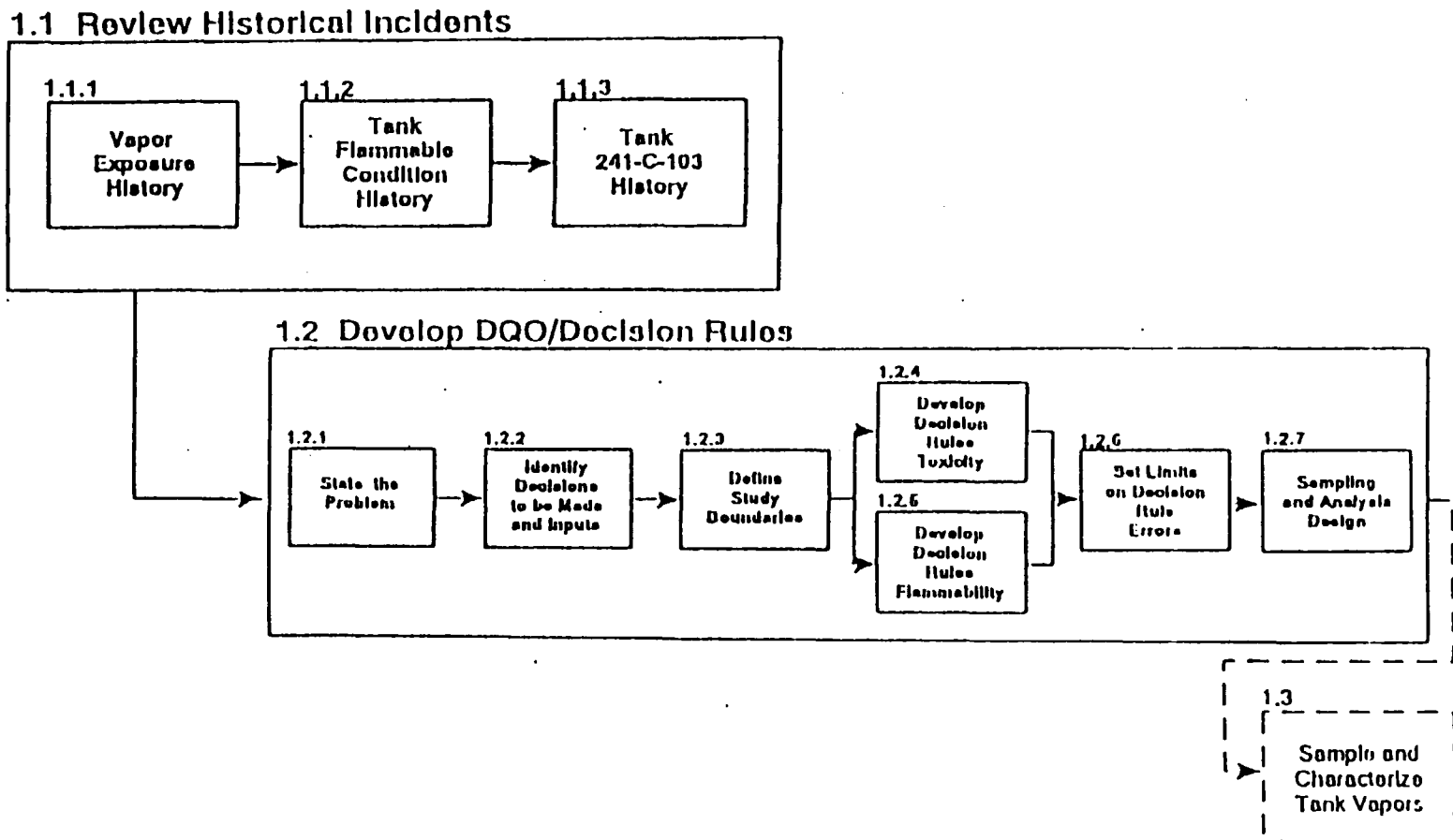
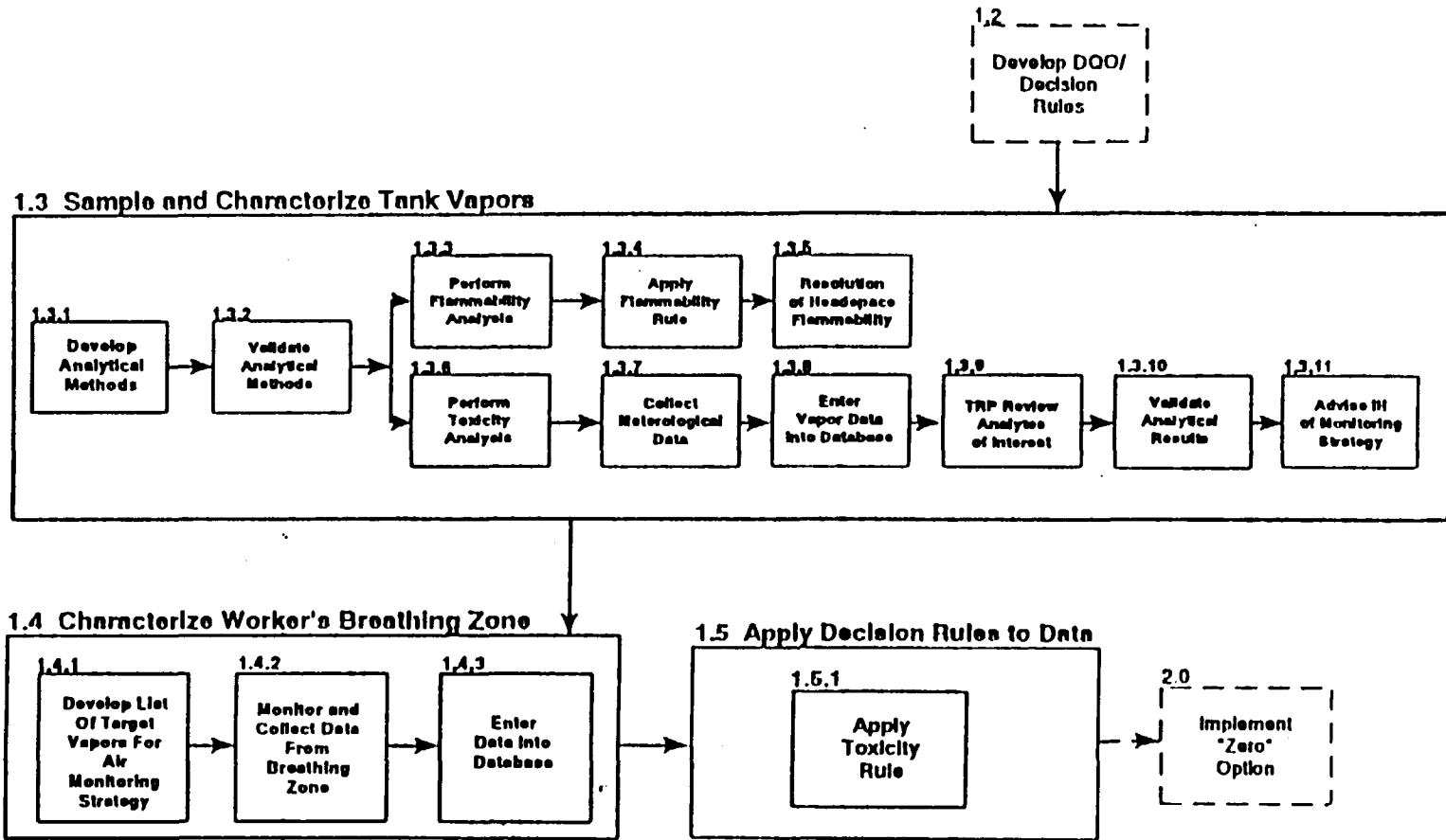

Figure 1-3. Overview of Waste Tank Safety Issue Resolution Logic. (2 of 2)



The primary expectations of the DQO planning team were to adapt the approach and methods from previous DQOs and determine the right number and types of samples and analyses needed to screen for vapor safety problems for tank farms in general. It is expected that this vapor safety screening DQO will evolve and change with time. As data becomes available from 1) the characterization of suspect tanks which are governed by the In-Tank Generic Vapor DQO 2) routine use of the in situ vapor system (ISVS), and 3) subsequent studies address spatial and temporal variability, the nature of tank headspaces and their dynamics will come into better focus. This will enhance our understanding of the tank characterization problem and types/number of samples needed to address the problem. Prior to each new vapor sampling event, each sampling and analysis plan will be reviewed by the Vapor Program Manager, and any significant changes will be discussed with the appropriate stakeholders to ensure that whenever possible, data adequate for decision making will be generated by the vapor sampling program.

2.0 DQO STEP 1: STATE THE PROBLEM

2.1 BACKGROUND AND SCOPE

The Tank Vapor Issue Resolution Program was established in 1992 to resolve the health and safety issues related to vapors associated with the high-level waste tanks at the Hanford Site. The issues stem from 1) an insufficient understanding of reported exposures of tank farm personnel to potentially unacceptable levels of noxious vapors; and 2) the concern that until the vapors in the waste tanks are well characterized, the risks to worker safety (flammable conditions) cannot be determined.

The charter of the Vapor Program has been extended to include the overall characterization of the vapor headspace of all passively ventilated single-shell tanks. This data is needed to complete TPA Milestone M-44 tank characterization. For this purpose, Ecology requires reporting of tank headspace source term levels of some 400+ hazardous chemicals listed in the Washington Administration Code. Additionally, information is needed by the Air Emission Inventory DQO to assess potential levels of tank source terms for Clean Air Act air permitting and inventory estimates.

High-level radioactive waste generated by processes at the Hanford Site has been stored since the mid-1940s in large underground storage tanks which are grouped into tank farms. Due to the variety of processes at the Hanford Site and the range of waste types stored in the tanks, the history and current inventory of each waste tank are unique. Likewise, each tank has a unique vapor matrix.

Twenty three vapor exposure events involving 40 workers at the Hanford Site have occurred between July 1987 and February 1995. During these events, workers have reported ill effects including headaches, burning sensation in nose and throat, nausea, and impaired pulmonary function while working around waste tanks at the Hanford project. Musty and foul odors, including the smell of ammonia, have been reported to emanate from several single-shelled tanks (WHC 1994). Ten of these occurrences, involving 18 workers, were linked to C Tank farm. In particular, tank C-103 was implicated with six of the reported occurrences.

The scope of this hazardous vapor screening effort conducted under the Tank Vapor Characterization Program includes two separate characterization sampling strategies: 1) The first involves the physical collection of vapor samples from outside the tank by transporting the vapor via heated sampling lines to the VSS system* and, 2) the second uses an in situ vapor sampling assembly inside the tank headspace using an ISVS* system.

VSS representative characterization involves the headspace vapor sampling process that was pioneered and developed at the site, primarily from characterization efforts at tank C-103. This characterization method (VSS) is documented in the Program Plan for the Resolution of Tank Vapor Issues

*The vapor sample acquisition methods for these two characterization elements are described in Section 7.6.

(Osborne 1994). Vapor signature characterization is a characterization method (ISVS) currently planned for deployment, and is the result of refinement of characterization design based on experience gained through the 57 vapor sampling events. As additional information becomes available, the DQO will be updated and revised as needed. As such, this DQO should be viewed as a living document which will evolve with future iterations.

2.2 PROBLEM STATEMENTS

2.2.1 Flammability Problem

Does the vapor headspace exceed 25% of LFL? If so, what are the principal fuel components?

The presence of flammable constituents in the vapors of Hanford waste tanks is a safety question that must be resolved prior to conducting any type of intrusive sampling, stabilization, or remedial activities in or around the tanks. At issue are the potential effects on the tank and the environment, should a fire result from these activities. Standard WHC safety practices* dictate that the flammability of the headspace of a tank must be measured and determined to be below 25% of the LFL before intrusive work may be conducted on any Watch List tank. This DQO addresses the initial safety of conduct of operating flammability measurement. It also addresses the extend fuel component identification and quantification from high flammable conditions (i.e., > 25% LFL).

2.2.2 Toxicity Problem

Are compounds of toxicological significance present in the tanks at such a level that the industrial hygiene group shall be alerted to their presence so adequate breathing zone monitoring can be accomplished and future activities in and around the tanks can be performed in a safe manner?

2.2.3 Approach to Problem Resolution

The tank-by-tank approach to resolving the vapor headspace issues must first address the potentially catastrophic issue of high flammability. Until initial headspace LFL is determined, a tank cannot be fully sampled and characterized. Combustible gas meter readings will be taken to determine the % LFL of the headspace vapor. If these readings indicate any potential problem, vapor headspace samples will be taken to determine the composition and concentrations of flammable constituents in the vapor.

With resolution of the actual flammability condition in a given tank headspace, appropriate safe operating procedures will be established and headspace vapors will be sampled to characterize potential human health toxicity of the vapors and further assess the long-term storage criteria. Dependent upon the identified vapor constituents and their concentrations, the industrial hygiene group will be advised of the presence of compounds of toxicological significance in a tank headspace. With this information in hand, the industrial hygiene group can devise health and safety procedures

*Derived from National Fire Protection Association LFL guidelines.

that will provide worker protection during subsequent sampling and operational activities. This will include personal monitoring to target compounds detected at levels of concern in the tank and to maximize the effectiveness of monitoring the worker breathing zones around the tanks. Additional long-term permanent engineering controls may then be designed based upon the characterization data to provide an ultimate barrier between the source and the worker.

The objective of this screening is not to determine the levels of all vapors present in the tank headspace, or even the levels of all vapor known to have toxic properties. Rather, it is to evaluate the levels of certain toxic vapors that are identified by the sampling and analytical methods chosen. The objective of this DQO is thus to specify which "certain" vapors need to be looked at. These are referred to as "target analytes of toxicological interest" (see Table 2-1).

Table 2-1. Target Analytes of Toxicological Interest

Compound	Sample Type
Acetone	SUMMA™ TST
Acetonitrile	SUMMA™ TST
Ammonia	Sorbent Trap
Benzene	SUMMA™ TST
1,3-Butadiene	SUMMA™
Butanal	SUMMA™ TST
n-Butanol	SUMMA™ TST
n-Dodecane	OVS CCT
n-Hexane	SUMMA™ TST
2-Hexanone	SUMMA™ TST
Methylene Chloride	SUMMA™ TST
Nitric Oxide	Sorbent Trap
Nitrogen Dioxide	Sorbent Trap
Nitrous Oxide	SUMMA™
Propanenitrile	SUMMA™ TST
Sulfur Oxides	Sorbent Trap
Tributyl Phosphate	CCT
n-Tridecane	OVS CCT
Vinylidene Chloride	SUMMA™ TST

Because the sampling methods chosen are not guaranteed to collect all vapors, this sampling effort should be considered a screening to determine if chemicals identified by the method are present at sufficient levels to pose a threat to employee health if allowed to escape from the tank. Although the level of vapors present outside of the tank is likely to be much lower than those observed inside the tank, a worst case assumption would be that vapors present outside the tank are at the same level as those inside the tank. Thus, it would appear that it should only be necessary to look for those chemicals identified by the method that are present above their consensus exposure standard (CES) level.

However, since most of the chemicals with identified CES levels have relatively high values (ppm to hundreds of ppm), setting a threshold of the CES would severely limit the amount of data obtained from the sampling and analytical process. On the other hand, lowering the threshold level does not significantly add to the analytical complexity and value until this level drops below about 0.1 ppm. For this reason, all chemicals which are identified by the sampling and analytical methods at either their CES level or 0.1 ppm, whichever is lower, will be evaluated. This should avoid unnecessary analytical costs looking for compounds of low toxicity at ppb levels, while ensuring that compounds with low CES levels are looked for at the CES level.

If chemicals with very low CES (ppb range) are identified by analytical methods and are on the target analyte list, i.e., benzene (CES = .1 ppm) then extended analysis will be conducted in this region of the spectrum down to a 100 ppb limit of detection. This extended analysis will be by exception. The data generated by this effort will be given to Tank Farm IH&S to assist them in their efforts to protect the health of employees working in the tank farms. While the analytical results from this effort will be utilized by IH&S in evaluating the potential for employee exposure to toxic chemicals, they will not be used to set control measures or implement personal protective equipment. This is due to two factors, both of which were noted above. First, the analytical results will not represent all possible toxic substances present in the tanks. Second, the levels measured in the tank headspace are not likely to represent employee exposure levels. The data obtained will thus be a useful tool to assist industrial hygienists in assessing the potential for employee exposures, but will be considered as screening data rather than a complete assessment of all toxic chemicals.

For these reasons, the accuracy of the data is not critical. Even if the results obtained are only within +/- 30%, these data should be sufficient for making industrial hygiene judgments about the need for employee monitoring. The time and money needed to improve sampling and analytical accuracy would not be justified, since no one actually enters the tank headspace, and the vapor levels present outside the tank will have to be reevaluated if the headspace analysis indicates a potential for employee overexposure.

3.0 DQO STEPS 2 & 3: IDENTIFY THE DECISIONS TO BE MADE AND INPUTS TO THE DECISION

Two key decisions will be made based on the data collected--a flammability decision and a toxicity decision.

3.1 FLAMMABILITY DECISION

If the flammable gas concentration in the headspace of any tank is greater than 25% of the LFL under steady-state conditions, as measured by the combustible gas meter and/or potential sampling and analysis, then all operational and sampling activity should stop until the problem is investigated and resolved. If the flammable gas concentration in any tank is between 10 and 25% of the LFL in the headspace under steady-state conditions, then work may continue, but a sample will be collected and analyzed to determine the constituents and concentrations of the flammable constituents. Additional information pertaining to total organic carbon content may be determined in the field (real time) using an organic vapor monitor (OVM). If the flammable gas concentration in any tank is less than 10% of the LFL, then operational and sampling work may continue uninterrupted.

3.2 TOXICITY DECISION

If any compounds with toxicological properties exceed their respective trigger points inside the tank, then advise the industrial hygiene group that compounds of toxicological concern are present in the tank headspace. A trigger point is defined as 100% of the appropriate CES concentration for all chemicals or 0.1 ppm which ever is lower.

A CES is generally defined as the most stringent of known regulatory or recommended toxicological values for the occupational setting including the threshold limit value (TLV), permissible exposure limit (PEL), recommended exposure limit (REL). For those constituents with unknown toxicological values, the WHC Vapor Review Committee (VRC) comprised of toxicologists, industrial hygienists, and occupational medicine physicians will be responsible for development of a CES.

3.3 INPUTS TO THE DECISION

Initial input of historical data on headspace and waste temperature and initial screening data on LFL and headspace humidity will be needed to choose the best sampling method, either VSS or ISVS, for the final characterization. Initial screening will be ISVS based (see Table 3-1 for summary of decision inputs).

Table 3-1. Summary of Decision Inputs.

Decision Input	Decision	Reason for Requesting Decision Input
Vol% hydrogen	1A. Are gases above 25% of the LFL?	Hydrogen is considered to be the major contributor to the flammability of the tank dome space.
Vol% ammonia	1A.	Ammonia is another contributor to the flammability of the dome space.
Vol% methane	1A.	Contributor to flammability.
Vol% CO	1A.	Contributor to flammability.
[Ammonia]	1B. Are gases above noxious vapors limit?	Respiratory and eye irritant.
[CO ₂]	1B.	Simple asphyxiant.
[CO]	1B.	Replaces oxygen in blood.
[NO]	1B.	Respiratory irritant.
[NO ₂]	1B.	Respiratory irritant.
[N ₂ O]	1B.	Respiratory irritant.
Total organic carbon (TOC)	1B.	The presence of TOC in the vapor indicates that other noxious organic vapors could be present.
[Tributyl Phosphate]	1C. Is there an immiscible organic phase?	One of three dominant semivolatile compounds found in past tanks that have been vapor sampled. Indicative of a potential immiscible organic phase in the waste.
[n-dodecane]	1C.	Same as [tributyl phosphate] justification.
[n-tridecane]	1C.	Same as [tributyl phosphate] justification.

[] = Concentrations

The decision inputs summarized in Table 4-1 for decision Steps 1A, 1C, 2, and 3 are referenced in Meacham et al. (1995a). The toxicological compounds from decision Step 1B are referenced in Huckaby and Story (1994).

3.3.1 Flammability Decision Inputs

The primary flammability data input will be via combustible gas meter readings, and in some cases, additional determination of the concentration of flammable constituents in the headspace via an OVM. ISVS vapor collection and targeted fuel component analysis may be required.

3.3.2 Toxicity Decision Inputs

The following data needs are associated with the toxicity decision:

- Identification of chemical compounds of worker health and safety or toxicological importance in the headspace of the tank.
- Estimates of the concentrations of these toxicologically significant compounds in the headspace.
- Understanding of the toxicological effects of these compounds and the CES for each constituent of concern.

3.3.3 Development of Consensus Exposure Standards

CESs will be generated for each compound of potential toxicological interest detected in the vapor sampling effort. Industrial hygienists have several sources of information for exposure standards against which sampling results may be compared in order to determine whether or not an unacceptable exposure condition exists. A primary source is the American Conference of Governmental Industrial Hygienists (ACGIH) recommended TLVs with some 700 chemicals listed. For compliance purposes, the PELs listed in Subpart Z of the Occupational Safety and Health Administration (OSHA) regulations are used (29 CFR 1910.1000). The National Institute of Occupational Safety and Health (NIOSH) has developed RELs based on recent research and new information about the chemicals, and these RELs are intended for adoption into OSHA regulations. The American Industrial Hygiene Association (AIHA) has also developed Workplace Environmental Exposure Level (WEEL) guides on chemicals for which no current exposure guidelines at the time have been established by other organizations.

In selecting appropriate exposure limits for the chemical constituents in the tank farm headspace vapor, the VRC will first consult the ACGIH TLV booklet, the OSHA PEL tables, the NIOSH list of RELs, and the AIHA WEELs. The most stringent standard among the above sources will be used.

A chemical may not have published exposure standards. In this case, the VRC can provide a best estimate of the level of acceptable exposure to the chemical. This process for derivation of a consensus exposure limit must rely heavily on professional judgement of the VRC at Hanford. It may involve an initial literature search in various databases for available information on the chemical. Current data bases may include:

- Registry of Toxic Effects of Chemical Substances
- National Air Toxics Information Clearinghouse
- Integrated Risk Information System
- Gene-Tox Database through the National Library of Medicine
- MEDLINE
- TOXLINE

Evaluation of health effects may involve a search of information about the chemical or similar analogs on adverse effects, thresholds, possible evidence of carcinogenicity, genotoxicity, developmental toxicity, reproductive toxicity, systemic toxicity, and skin/eye irritation. The no-observable--adverse-effect-level (NOAEL), if available, may be useful for animal-to-human extrapolation. Another numerical value for consideration is the maximum tolerated dose. Generally, factors considered in the toxicity evaluation of a chemical may also include its pharmacokinetic properties, effects on target organs metabolism (biochemical reaction and transformation), and the rate of absorption and distribution. For example, when considering route-to-route extrapolation, the limitations of extrapolation are clearly apparent and one must account for:

- Difference in absorption efficiency
- Difference in systemic effects
- Occurrence of critical toxic effects at portal of entry
- First-pass effects that may result in either bioactivation or detoxification of a chemical prior to reaching the target organ
- Variations in the time course of target organic concentrations of toxicologically active species

In addition, other factors may include known specific chemical interactions, severity of effects, and other significant effects. The VRC will make various assumptions based on professional judgement to understand toxicological effects for chemicals with little or no known toxicity information. To support the tank farm vapor program, the VRC will apply methods that are scientifically defensible, short of conducting research, to formulate a recommended CES for those chemicals. Insofar as possible, the same approach that AIHA uses in establishing WEELs will be used to evaluate new chemicals.

4.0 DQO STEP 4: DEFINE STUDY BOUNDARIES

Vapor sampling will be eventually conducted on all passively ventilated tanks in the tank farm complex at Hanford. This DQO differentiates tanks on the current "Suspect Tank List," and all other passively ventilated tanks. It further differentiates between those identified as suspect tanks that are actively ventilated, and those that are not. Because of the active ventilation on all DSTs, their stack sampling and characterization are not included in the scope of the hazardous vapor screening DQO.

The spatial boundaries of both the flammability and toxicity decisions for any non-actively ventilated tanks are essentially the internal dimensions of the tank above the level of waste in the tank and not physically inside the dimensions of the riser. This volume is known as the "headspace" of the tank. Due to tank access restrictions that limit access to most of this volume, flammability and toxicity decisions for most tanks will be based on samples taken from a single location at a point approximating the midpoint of the tank headspace volume. If a case of suspected non-convective mixing arises, the ISVS technology can be adapted to allow vapor samples to be taken at numerous vertical locations through the headspace. This will facilitate a vertical vapor concentration profile to address potential stratification.

Concentrations of constituents in the vapor are not predicted to fluctuate greatly over time (some minor seasonal variation is expected), and constituents of interest in the vapor are assumed to be homogeneously distributed (well mixed) within the headspace. Accordingly, a special study effort to consider the effects of diurnal, seasonal and long-term changes in headspace concentrations will be conducted in FY 1996 to support this supposition. Until these studies are completed on other SSTs, measurements of vapor constituents from anywhere within the headspace (below the risers) are assumed to be representative. If and when results of special studies taken over time and at four depths in the headspace refute these assumptions, the boundaries for this DQO will be revisited and the design for sampling will consider these sources of variability.

5.0 DQO STEPS 5: DECISION RULES

The specification of decision rules for each of the identified decisions is a critical step in the DQO process. The decision rule combines the earlier statements into a single statement which specifies how data will be used to make each specified decision.

5.1 FLAMMABILITY DECISION RULE

The flammability decision rules are stated below. The logic applied to the flammability decision is illustrated in Figure 1-1.

1. If a single sample of tank vapor fuel content, as measured below the riser with a combustible gas meter (CGM), is greater than 25% of the LFL, then the tank is declared a potential flammability hazard and all operational and sampling activity shall cease until the flammability problem is investigated and resolved by the Plant Review Committee.
2. If a single sample of tank vapor fuel content, as measured below the riser with a CGM, is greater than 10% but less than 25% of the LFL, operational and sampling activity may continue under combustible gas monitoring, and samples will be collected from the headspace to determine the vapor constituents and concentrations of the potentially flammable mixture.
3. If a single sample of tank vapor fuel content, as measured below the riser with a CGM, is 0 to 10% of the LFL, then the tank is not considered a flammability risk and work can proceed.

Rationale of Decision Rule

The flammability issue for waste storage tanks centers around three potential fuel sources: flammable vapors, flammable floating liquid or interstitial layers (interim stabilized salt cake tanks which formally held a surface floating organic layer) and flammable gases (e.g., H₂). This DQO process addresses only the data used to evaluate the flammability of the headspace due to combustible components (i.e., vapors and gases) which may impact the safety of operations. The flammability of a floating liquid or interstitial layer is addressed separately in the Organic DQO document number PNL-8871. Industrial standards for the chemical and gas industries have been adapted for use as guidelines in the Hanford tank farm complex. The WHC control manual and plant operating procedure level is the industrially accepted standard of 25% of LFL. This level is a warning that some condition or process has changed and that some action is needed before operations are continued. The current practice is to measure the LFL^(*) and if >25%, then stop work, sample, analyze, and convene the Plant Review Committee (PRC) for review. Their options are to allow continued operation up to some predetermined higher level like 50% LFL or to require dilution or mitigation to reduce the LFL level to below 25% LFL. This logic drives the demand for highly reliable flammability data and a

*National Fire Protection Association recommends that processes be controlled at this LFL %.

definitive decision rule.

5.2 TOXICITY DECISION RULE

The DQO team established decision rules based upon chemical CES and a generic concentration of concern which ever is lower. The decision rule is specified below. The IF/THEN logic applied to the toxicity decision is illustrated in Table 5-1.

If the average concentration of any chemical in a tank headspace is at 100% of its CES or 0.1 ppm, whichever is lower, then the industrial hygiene group will be advised that a compound(s) of toxicological concern is (are) present in the tank headspace. IH&S can then target these analytes for their air monitoring program. Ultimately, data will be generated on the levels of these analytes in the workers' breathing zone. Appropriate worker protection actions can then be taken.

Rational for Decision Rule

For the average concentration of any chemical a 1.0 safety factor is used for irritants, carcinogens and systemic toxicants. It should be noted that complex mixtures of compounds will be evaluated on a case-by-case basis by the VRC. Grouping of like compounds and the application of mixture rules will be applied by the VRC to generate combined CESs for toxicity assessments.

The concentration measurements are for chemicals in the tank headspace not the workers' breathing zone. The industrial hygiene action level concentrations of 50% of CES will be applied to industrial hygiene monitoring data.

If any compounds of toxicological interest are tentatively identified by Phase 1 initial vapor screening, the VRC may classify the problem as either organic or inorganic (e.g., NH_3 , HCN), and require a more extensive extended analyses of the reserved set of samples for representative characterization (see Section 7.6). In general, constituents greater than 50% of their Immediate Dangerous to Life or Health (IDLH) will trigger this action. In addition, the VRC will evaluate the potential adverse effects of complex mixtures as described above, and may request additional samples as appropriate.

Table 5-1. Decision Rule.

Step No.	Decision No.	IF (Decision Threshold)	THEN
1.	1A.	LFLA \geq 25% (LFLA is Lower Flammability Limit Approach - See below for definition)	Implement controls for flammable gas Watch List tank (Schofield 1995). Notify Flammable Gas Safety Program. Continue to next step.
2.	1B.	[Ammonia] \geq 25 ppm AND/OR [CO ₂] \geq 5000 ppm AND/OR [CO] \geq 35 ppm AND/OR [NO] \geq 25 ppm AND/OR [NO ₂] \geq 1.0 ppm AND/OR [N ₂ O] \geq 25 ppm AND/OR [TOC] \geq 1.0 ppm	Restrict workers from area. Go to DQO for Generic In-Tank Health and Safety Vapor Issue Resolution (Osborne 1994a). Notify Noxious Vapor Safety Program. Notify Industrial Hygiene. Continue to next step.
3.	1C.	[Tributyl phosphate] \geq detection limit AND/OR [Dodecane] \geq detection limit AND/OR [Tridecane] \geq detection limit	Implement controls for Organic Watch List tank (Schofield 1995). Go to Organic DQO (Buckley 1995). Notify Organic Safety Program. Continue to next step.
4.	2.	Continuous aqueous layer observed on waste surface.	Tank is under safe storage conditions.* -Monitor waste surface to ensure safe interim storage. -Stop here.

[] = Concentrations

* See (Meacham et al. 1995a).

6.0 DQO STEP 6: LIMITS ON DECISION ERRORS

Limits on decision errors were elicited to provide a criteria against which to measure the expected performance of alternative designs. Decision errors and corresponding tolerances developed for the in-tank generic vapor DQO will apply to the remainder of any new "Suspect" List tanks revealed by safety screening. No attempt to specify limits on decision errors for signature characterization events was made by the planning team.

6.1 DEVELOPMENT OF FLAMMABILITY DECISION ERROR LIMITS

The process of specifying limits on decision errors begins by identifying each type of potential decision error and discussing the consequences associated with these error types.

One type of decision error would occur if data indicate that the observed $LFL_{MIX} > 25\%$ (flammability is a concern), when the "true" LFL_{MIX} is $< 25\%$ (as determined by additional vapor sampling for any reason). If this occurs, work will be stopped, a safety review will be implemented unnecessarily, and a more complex analysis of LFL will be conducted. These actions would result in the following consequences:

- Increased costs
- Schedule delays
- Possible negative impact on critical path
- Credibility loss.

A second kind of decision error would occur if data indicate that the observed $LFL_{MIX} < 25\%$ (no concern with flammability), when the "true" LFL_{MIX} is $> 25\%$. If this occurs, then additional sampling will proceed with sampling methods that could introduce ignition sources to the headspace.

This decision error is of MAJOR CONCERN and has the following consequences:

- Potential negative safety implications
- Increased costs
- Possible continued use of unacceptable operating techniques.
- Credibility loss

Desired Performance Curve Inputs

After identifying the decision errors and their associated consequences, the planning team considered a series of potential error scenarios (presumed true LFL values) and specified their aversion to these specific potential decision errors in a desired performance (Table 6-1).

Table 6-1. Desired Performance for the Flammability Decision

Presumed true fraction of the LFL	Acceptable probability of deciding to stop work
less than 0.15	≤ 50%
0.15 to 0.25	-
0.25 to 0.50	≥ 90%
more than 0.50	≥ 99%

6.2 DEVELOPMENT OF TOXICITY DECISION ERROR LIMITS

One type of decision error—would occur if we observe that the action level (100% of the CES for all chemicals) has been exceeded, when, in fact, the "true action level" has not been exceeded. If this decision error occurs, then worker protection control measures and breathing zone air monitoring requirements may be over-prescribed or misdirected, resulting in the following consequences:

- Increased costs
- Increased risk of injury or illness to workers resulting from the wearing of personal protection equipment in extreme temperature conditions
- Credibility loss
- Scheduled delays.

A second type of decision error would occur if we observe that the action level (10% of the CES for all chemicals) has not been exceeded, when in fact the "true action level" has been exceeded. If this decision error occurs, then workers could potentially be exposed to toxic levels of vapor. This decision error is of major concern and would result in the following consequences:

- Potential worker illness
- Credibility loss
- Increased costs
- Liability to WHC/DOE.

Desired Performance Curve Inputs

Three different sets of constituents were considered independently due to the types of consequences and differences in action levels. Tables 6-2, 6-3, and 6-4 depict the decision error limits established during the DQO development exercise. Since the consequences were most severe for carcinogens, the error tolerances were tightest for these constituents. In all likelihood, these constraints will drive the sampling and analysis design. In fact, the analytical experts predicted that a design adequate to determine if benzene

exceeded its CES would be more than adequate to make decisions for all other constituents of concern.

Table 6-2. Desired Performance for the Toxicity Decision: Average Concentration of Confirmed/Suspected Human (Class A1/A2) Carcinogenic, Teratogenic or Mutagenic Constituents

Presumed "True" Fraction of the CES	Acceptable Probability of Deciding Toxic Constituents Are Present
less than 0.01	≤ 1%
0.01 to 0.05	≤ 20%
0.05 to 0.1	-
0.1 to 0.5	≥ 80%
0.5 to 1	≥ 95%
1 or more	≥ 99%

Table 6-3. Desired Performance for the Toxicity Decision: Systemic Toxicant Constituents

Presumed "True" Fraction of the CES	Acceptable Probability of Deciding Toxic Constituents Are Present
less than 0.05	≤ 1%
0.05 to 0.25	≤ 25%
0.25 to 0.5	-
0.5 to 1	≥ 50%
more than 1	≥ 90%

Table 6-4. Desired Performance for the Toxicity Decision: Irritant Constituents

Presumed "True" Fraction of the CES	Acceptable Probability of Deciding Toxic Constituents are Present
less than 0.05	≤ 1%
0.05 to 0.25	≤ 25%
0.25 to 0.5	-
0.5 to 1	≥ 35%
1 or more	≥ 50%

7.0 SAMPLING AND ANALYSIS DESIGNS FOR OBTAINING DATA

7.1 STATISTICAL TERMINOLOGY

The performance tables in Section 6 provide a tool for the decision makers to describe the acceptable probability of making a decision error. The theory behind these tables is based on statistical hypothesis testing, in which the data are used to decide between one condition of the environment (the null hypothesis, H_0) and an alternative condition (the alternative hypothesis, H_A) the null hypothesis is assumed to be true in the absence of strong evidence to the contrary. A decision error occurs when the decision makers are led to believe in one hypothesis when the other is true.

There are two types of decision errors that must be considered. The first type of decision error occurs when the decision makers conclude, based on the data, that H_0 is true when, in fact, H_A is true. This error is sometimes referred to as a false positive, or a Type I, error. When the decision makers specify how often they can tolerate making this type of decision error (e.g. 5 out of 100 times), that is often referred to as the Type I error rate, or α . The second error occurs when the decision makers conclude, based on available data, that H_0 is true when, in fact, H_A is true. This error is sometimes referred to as false negative, or Type II, error. The Type II error rate, or β , is the specification of how often the decision maker can tolerate making this type of decision error.

7.2 DESIGN ASSUMPTIONS

For each vapor sampling event, the flammability and toxicity decision rule will both be addressed. The two assumptions of importance are that the headspace is anticipated to be relatively homogeneous, and that the total study error is approximately equal to measurement error.

7.3 SELECT THE APPROPRIATE STATISTICAL TEST

The hypotheses and statistical tests developed for C-103 heated tube flammability determinations are applicable for hazardous vapor screening for flammability determinations that are based on the analysis of flammable constituents. For most tanks, the expected value of the CGM is expected to be well below 10% of the LFL. In these cases, a direct comparison of the measured value to 10% of the LFL will be used; hence no statistical test will be conducted.

The hypotheses for the toxicity decision rule for carcinogens are distinguished by a comparison of the average concentrations of confirmed or suspected human (class A1 or A2), carcinogens (this includes teratogens and mutagens) to their corresponding action level (0.5 times the CES for carcinogens). The goal of the testing procedure is to determine if there is sufficient evidence in the collected data to reject the hypothesis that the average concentration of carcinogens is greater than the action level. The appropriate classical statistical test for resolving this problem is a one sided t-test. The hypotheses can be stated as follows:

H_0 : Mean concentration of each carcinogen > 0.5 times CES

H_A : Mean concentration of each carcinogen < 0.5 times CES.

The desired performance (Table 6-2) indicates that the specified probability of deciding toxic constituents are present at the hypothesis boundary of 0.5 times CES is 0.80. Since this corresponds to making the correct decision when the null hypothesis is true, the probability of making an incorrect decision when the null hypothesis is true (i.e., the probability of deciding H_A when in fact H_0 is true) is one minus 0.80, or 0.20. Thus, the Type I error rate, or α , is 0.20 (i.e., the probability of deciding that toxic constituents are not present when, in fact, they are, is no greater than 0.20). Also indicated is that the probability of deciding to stop work at 0.05 times the CES should be $<$ to 0.20. Since this corresponds to making an incorrect decision when the alternative hypothesis is true, the Type II error rate at 0.05 times CES, or C at 0.05 times CES, is 0.20 (i.e., the probability of deciding that the toxic constituents are present when, in fact, they are not, is no greater than 0.20). The region of decision indifference is defined in the desired performance curve at 0.05 to 0.10 times CES.

The hypotheses for the toxicity decision rule for systemic toxins and for irritants are distinguished by a comparison of the average concentrations of systemic toxins or irritants to the action level of 0.5 times its CES. The appropriate classical statistical test for resolving these problems is a one sided t-test. The hypotheses can be stated as follows:

H_0 Mean concentration of each systemic toxin $\geq 0.50 \times$ CES

H_A : Mean concentration of each systemic toxin $< 0.50 \times$ CES

and

H_0 Mean concentration of each irritant $\geq 0.50 \times$ CES

H_A : Mean concentration of each irritant $< 0.50 \times$ CES

The desired performance curves for these decisions are found in Tables 6-3 and 6-4. Using the same discussion as for carcinogens, the Type I error rate, or α , for these constituents is 0.05. The Type II error rate at 0.25 times CES, is 0.25. The region of decision indifference is between 0.25 and 0.5 times CES.

7.4 OBTAIN PERTINENT ESTIMATES OF UNCERTAINTY

No estimates of uncertainty were available for the measurement error for the FC_{Mixture} . As data appropriate for obtaining pertinent estimates of uncertainty become available from C-103 and for other Suspect List tanks, revisions to the statistical sampling design will be considered. Until that time, professional engineering based designs will be used to obtain samples for decision making.

Estimates of uncertainty for the toxicity decision rule also do not exist at this time. Engineering judgement estimates of the important sources of uncertainty could be obtained, but none of the estimates can be directly tied

to observed data.

7.5 POWER ANALYSIS

No power analyses were performed for either the flammability or toxicity decision rules because no prior estimates of uncertainty were available. A retrospective power analysis could provide a useful look at the achievable probabilities of decision error as estimates of uncertainty become available.

7.6 VAPOR SAMPLE ACQUISITION METHODS

Two methods will be used to collect gas and vapor samples for the waste tanks. The first method, Type 3 or VSS (see Figure 7-1), employs heated transfer tubing, a heated sampling manifold, relatively sophisticated temperature, flow control, and valving technology, and a vacuum pump to draw air, gases, and vapors out of the waste tanks. Different types of samples can be taken from several stations of the manifold, which is housed with the measurement and control equipment in a climate controlled mobile laboratory. This method currently requires that a special vapor sampling probe be installed by crane into a riser of the tank. The integrated equipment (e.g., probe, heated transfer tubing, and everything in the mobile laboratory) is referred to as the Vapor Sampling System or VSS. Vapor samples are collected either by SUMMA™ canisters or sorbent traps.

The VSS was specifically designed to collect representative samples from warm, moist tanks, even if there is a fog in the headspace. Advantages of the VSS include the abilities to perform sampling in adverse weather conditions, to house real-time analytical equipment, and to address high concentrations of organic vapors. Problems yet to be fully addressed include the potential adsorption and loss of certain species on the walls of the transfer lines. This system is currently used for the collection of vapor samples from all suspect Watch List tanks in fiscal year 1995 and will be held in reserve for special studies of tanks identified by ISVS hazardous vapor screening in fiscal year 1996.

The second and primary vapor screening method, Type 4, for collecting gas and vapor samples from the waste tanks is referred to as In Situ Vapor System (ISVS) (see Figure 7-2). Rather than transferring the air, gases and vapors to be sampled to a remote location, the sampling devices themselves (specifically sorbent trap bundles) are lowered down into the headspace of the tank. This assures more representative sample collection and avoids transport efficiency problems associated with the loss of analytes via wall adsorption. Whole air SUMMA™ canister samples for permanent gas analysis are also collected via this system, but are external to the tank.

The ISVS method uses simple, inexpensive digital mass flow measurement and control equipment, which currently is mounted on a 2-wheel hand cart. The required equipment is easy to maintain and duplicate. The ISVS method

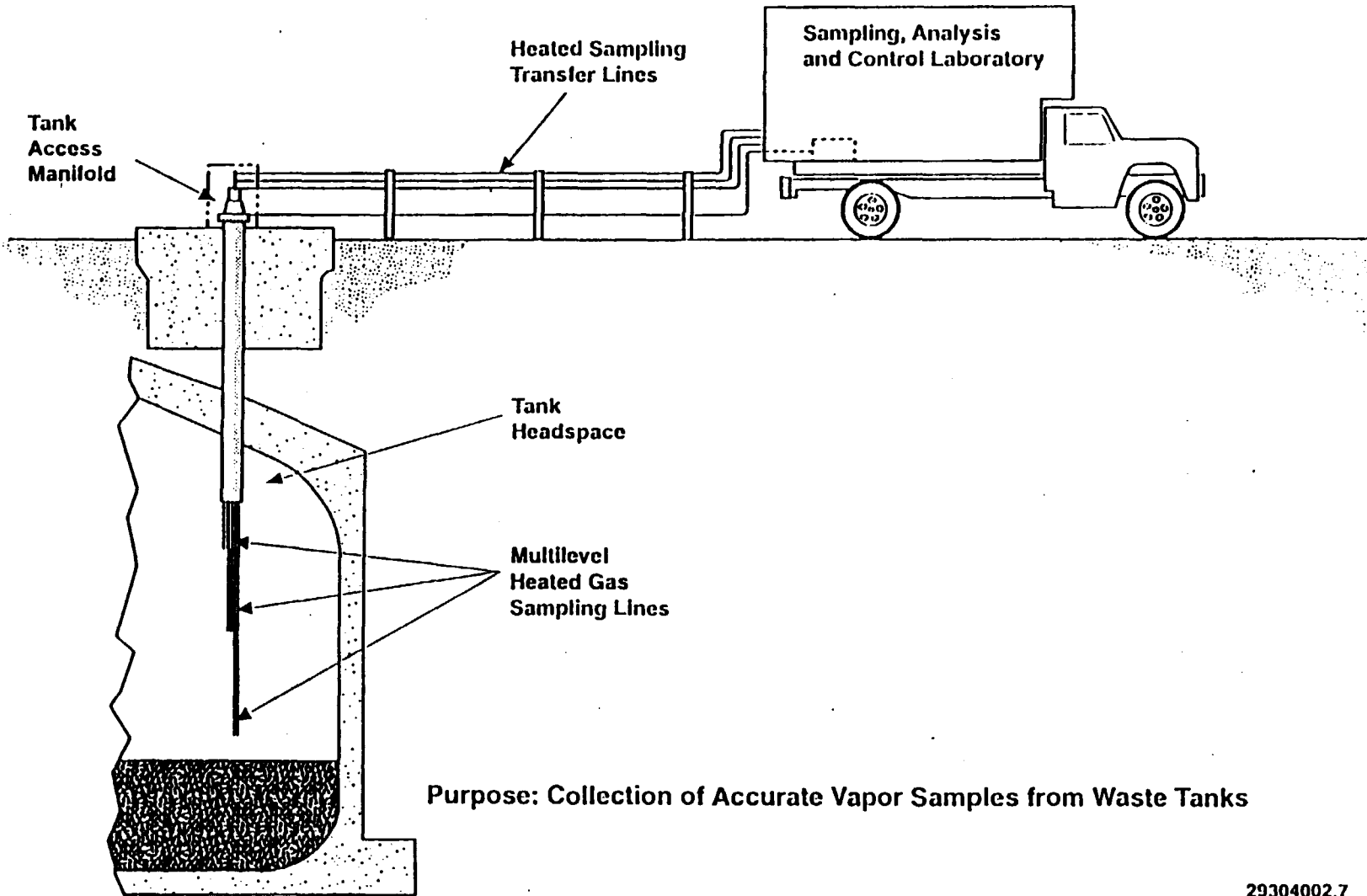
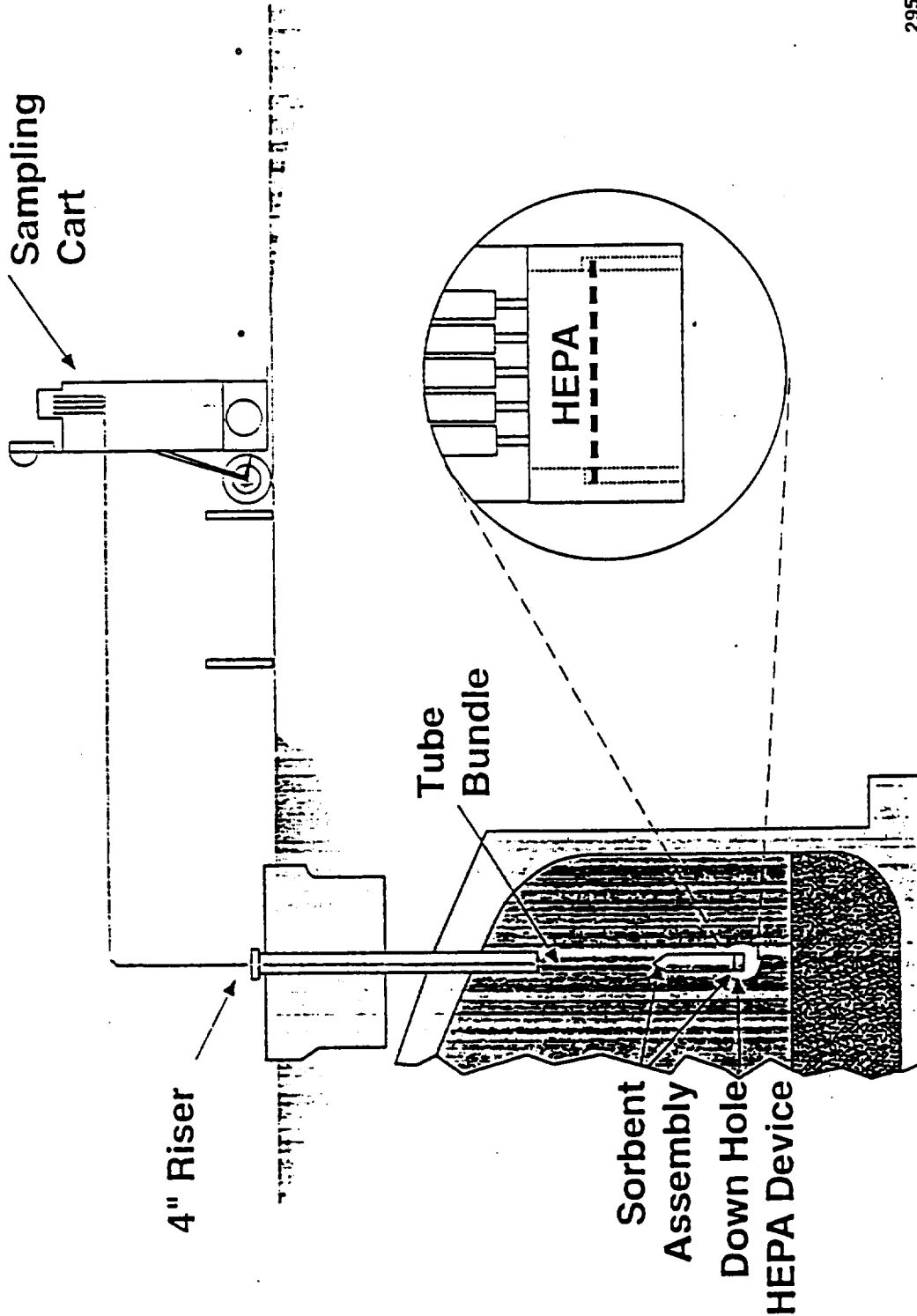

Figure 7-1. Vapor Sampling System

Purpose: Collection of Accurate Vapor Samples from Waste Tanks

29304002.7

Figure 7-2. In Situ Vapor System



29504024.1C

provides the ability to collect samples quickly and without the special sampling probe of the VSS. Disadvantages of the ISVS method include current limitations on its ability to sample some volatile organic vapors under certain conditions (e.g., acetone in a high-humidity tank) and that each sampling event involves breaking the containment of the tank. The shipment and analysis of ISVS sorbent traps is also currently dependent on proving no radiolytic contamination of the traps has occurred.

A limited ISVS event that addresses the most significant noxious gases and vapors, requiring less than three hours at an open tank riser, is planned for each remaining uncharacterized passively ventilated single-shell waste tank. These sampling events are currently designed to collect triplicate sorbent trap samples of ammonia, nitrogen dioxide, nitrogen monoxide, and water vapor. Additionally, triplicate SUMMA™ canister samples will be collected from the same vicinity as the other samples via an unheated tube, and will be analyzed for volatile organic vapors. Potential radiolytic contamination of the sorbent traps will be addressed by simultaneously collecting a OVS trap for sacrificial radiolytic analysis. If a tank is identified as warm and humid, based upon screening, the VSS may be reactivated to sample and characterize the tank.

7.7 ADAPTIVE ANALYSIS STRATEGY

For the hazardous tank vapor screening analysis, the following adaptive analytical strategy will be employed.

If a flammable safety concern tank is identified by vapor screening, special study in situ sorbent sampling using OSHA Versatile Sampling and analysis technology as described in "Aerosol and Vapor Characterization of Tank 241-C-103" (PNL-8875/UC-606) or equivalent will be employed for resolution.

If the tank is safe to sample, a representative sample of the tank headspaces will be taken in a manner that has been shown to be effective to address any documented concerns and the DQOs for that tank, (SUMMA™ canisters and sorbent tubes). Standard, accepted, ambient air analysis methodologies such as chemical class detectors (hydrocarbon, halogen, etc.), gas chromatography, mass spectrometry, ion chromatography or colorimetry will be employed to determine concentrations above 100 parts per billion (volume). The analysis will specify by chemical the concentration detected and the confidence of that measurement. Historically achieved performance can be substituted for non-standard gases. If the list of tentatively identified compounds (TICs) contains any analytes that are of concern to the program; e.g., toxicity, those concerns will be addressed and judged by the VRC with respect to the data and a determination made as to the adequacy of the sampling and analysis or whether additional work needs to be done. This may mean the convening of an expert panel, operational controls or other resolution means that are cost effective.

The analytical strategy for hazardous vapor screening is a iterative phased approach. The preferred sample collection method is the Type 4 ISVS cart utilizing a down hole vapor sampling bundle which can collect vapor from any

Comprehensive Hazardous Vapor Safety Screening Program

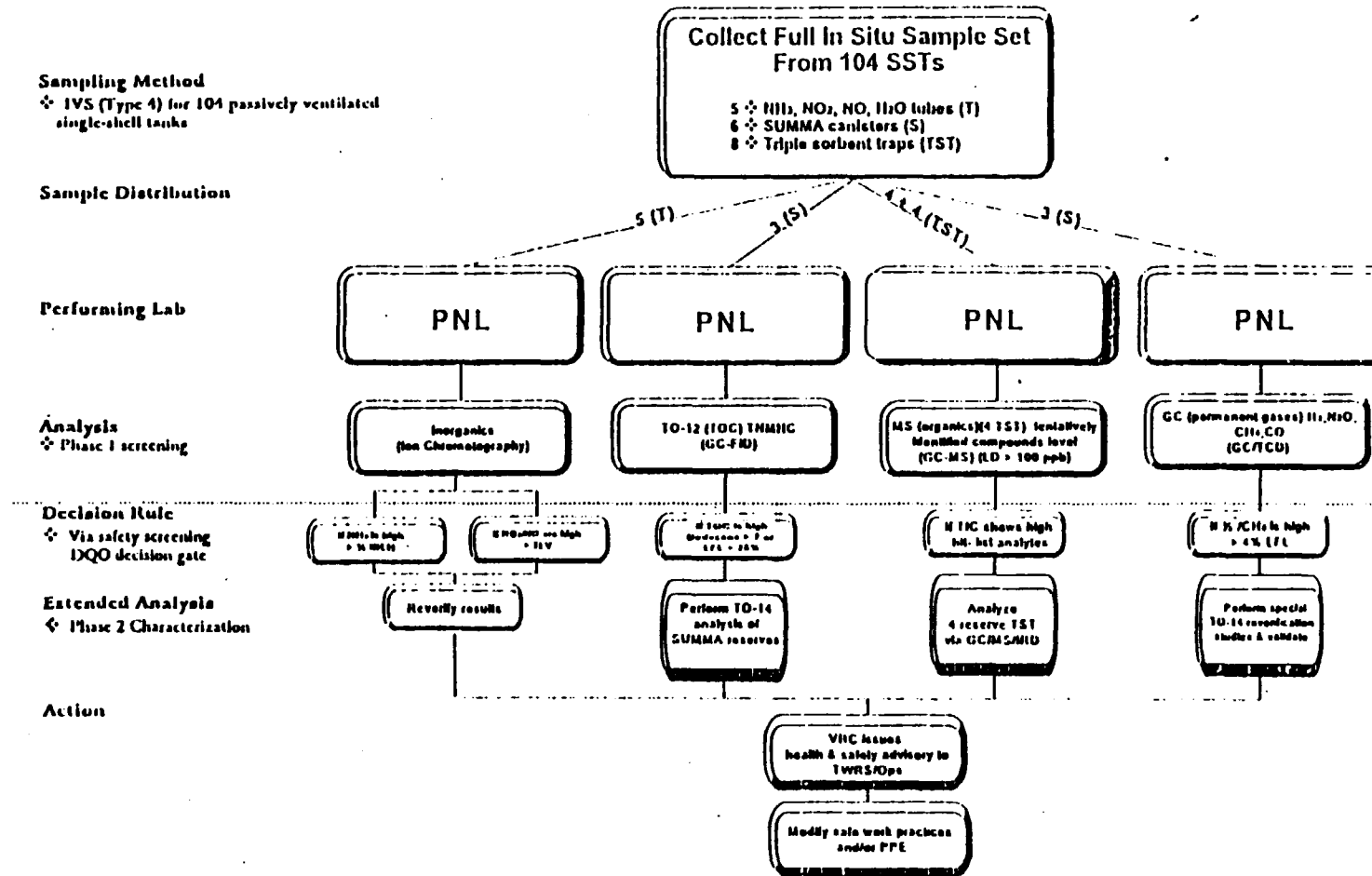

Figure 7-3. Comprehensive Hazardous Vapor Safety Screening Program

Vapor Review Committee (Industrial Hygiene, Toxicology, Industrial Safety, IHEIF Occupational Medicine)

vertical height between the bottom opening of the riser in the headspace to within millimeters of the waste surface.

The sampling strategy is to collect a complete vapor sample set which can be used to complete the initial hazardous vapor screening and ultimately to complete full definitive characterization of the tank's headspace if warranted. This "standard" sample set is described in Table 7-1.

The concept is to sample a tank once and iteratively analyze the samples to the degree necessitated by the findings. An example is to collect a "standard set" of five NH_3 sorbent traps from each tank. Phase 1 initial screening will analyze two traps as a screening set. If the level of NH_3 is well below the CES (TLV = 25 ppm), then stop analysis and discard the remaining traps. However, if the level is at 50% of IDLH (IDLH = 300 ppm) then additional confirmation analysis of all NH_3 traps is warranted. The strategy allows for additional sample analysis as directed by confidence levels as the action level is approached. Because the maximum number of samples needed were collected during the sampling event, resampling is not needed. Because of the high cost and time penalty for lab analysis, this strategy offers the greatest economy while generating the right amount of data which is defensible to TCP accuracy and precision requirements. This concept is collectively described as "right data at right confidence at minimum time and cost." This logic is depicted in Figure 7-3.

In the case of SUMMA™ canister samples for organics, Phase 1 initial screening will use EPA TO-12 (GC/FID) analysis to assign a TOC level to the tank. If the action level criteria presented in the TCP is exceeded, the VRC/TRC may request additional extended analysis of the sorbent traps for identification of the chemicals which comprise the TOC level. Based upon this information, these groups may again request extension of analysis to use EPA TO-14 (GC/MS/IR) methods to lower the limit of detection to 10 ppb. If the chemical is an analyte of toxicological interest (see Table 2-1), confidence in the data may be achieved by triplicate analysis of the reserved whole air SUMMA™ canister samples.

Table 7-1. Sample Chemical, Physical, And Radiological Analytical Requirements

VAPOR		COMMENTS				SEE TABLE 2 FOR NO. OF SAMPLE/BLANK CONTAINERS				
Plan Number	WHC-SD-WM-TP-335	Type 3 vapor sampling system (VSS) using heated vapor probes.	Early Notify	Organization	WHC	PNL	ORNL			
Generic:	Type 3 Vapor SAP for each tanks listed in section 2.0		Process Control	SUMMA® Canister ^a		X				
Program Contact	J. W. Osborne		Safety Screen	Sorbent Trap System ^b		X				
TWRS Contact	R.D. Schreiber		Waste Management	Triple Sorbent Trap				X		
Lab Project Coordinator	S. C. Goheen (PNL) R. A. Jenkins (ORNL)		RCRA Compliance	HEPA Filter	X					
		Special	Tritium Trap	X						

PRIMARY ANALYSES							CRITERIA				REPORT FORMAT
ANALYSIS METHOD	PRIMARY ANALYTE	PROCEDURE	LAB	SAMPLE PREP	SAMPLE CONTAINER	SURR SPIKE ^c	NOTIFICATION LIMIT (NL) ^d	EXPECTED RANGE	PRECN at NL	ACCURACY at NL	
EPA TO-14 GC/MS	Organic* Speciation	PNL-TVP-01 PNL-TVP-02 PNL-TVP-03	PNL	Direct	SUMMA®	none	≥ 700 ppmv n-Butanol 50% IDLH for all others*	not available	±25%	70-130%	I, VI
GC/TCD	CO ₂ CO CH ₄ H ₂ H ₂ O	PNL-TVP-05 PNL-TVP-02	PNL	Direct	SUMMA®	none	N/A ≥ 20% LFL ≥ 20% LFL ≥ 20% LFL not available	not available	±25% ±25% ±25% ±25%	70-130%	VI I, VI I, VI I, VI I, VI
IC	NO NO ₂	PNL-TVP-09 PNL-ALO-212	PNL	H ₂ O Extraction	Sorbent Trap	none	≥ 50 ppmv ≥ 10 ppmv	≥ 2 ppmv ≥ 0.1 ppmv	±25% ±25%	70-130%	I, VI I, VI
Gravimetric	H ₂ O	PNL-TVP-09	PNL	Direct	Sorbent Trap	none	N/A	≥ 3 mg/L	±25%	70-130%	VI
Selective Electrode	NH ₃	PNL-TVP-09 PNL-ALO-226	PNL	H ₂ O Extraction	Sorbent Trap	none	≥ 150 ppmv	≥ 2 ppmv	±25%	70-130%	I, VI
GC/MS	Organics**	AC-MM-1-033153 CASD-OP-300-WP03 CASD-OP-300-WP04 CASD-OP-300-WP05 CASD-OP-300-WP06	ORNL	Thermal Desorption	Triple Sorbent Trap	all	≥ 700 ppmv n-Butanol, 50% IDLH for all others**	not available	±25%	70-130%	I, VI
Total α Total β Total γ	Radon Daughters	LA-508-110 LA-508-111 LA-508-162	WHC	Direct	HEPA Filter	N/A	≥60 pCi/g α ≥200pCi/g β ≥200 pCi/g γ	<60 pCi/g α <200 pCi/g β <200 pCi/g γ	±25% ±25% ±25%	70-130%	I, II
Liq. Scin.	Tritium ^e	LA-548-111	WHC	Direct	Tritium Trap	N/A	N/A	not available	N/A	N/A	II
GC/FID	Organics	WHC-IP-1127(4.5)	SML	Direct	On-line	N/A	N/A	N/A	N/A	N/A	II, VI

N/A: Not Applicable

a No extra canisters, except archive, will be stored by PNL.

b System contains individual sorbent media sections for NO_x, NH₃, & H₂O.

c Samples spiked with surrogates.

d Action required if any compound exceed 50% IDLH.

e Survey purpose only.

*Acetone, acetonitrile, benzene, 1,3-butadiene, butanal, n-butanol, n-hexane, methane, propane nitrile. Other organic species detected at levels deemed sufficient by the Toxicology review Panel to be of potential toxicological concern shall be reported following Format I.

**Acetone, acetonitrile, benzene, butanol, n-dodecane, n-hexane, propane nitrile, tributyl phosphate, n-tridecane. Other organic species detected at level deemed sufficient by the Toxicology Review Panel to be of potential toxicological concern shall be reported following Format I.

A-41
30

WHC-SD-WM-DQO-002 Rev 1

Page LEFT INTENTIONALLY BLANK

8.0 REFERENCES

- Claybrook, S. W. and S. A. Wood, 1994, *Organic Evaporation in Waste Tank C-103*, WHC-SD-WM-ER-344, Rev. 0, Westinghouse Hanford Company, Richland, Washington.
- Dukelow, G. T., T. M. Brown, April 1995, *Data Requirements for the Safety Screening Issue Developed Through the Data Quality Objectives Process*, WHC-SD-WM-DQO-012, Rev. 0, Westinghouse Hanford Company, Richland, Washington.
- Gerton, R. E., C. O'Dell, 1992, *Review of the Westinghouse Plan for Controlling and Dealing with Noxious Gases in the Tank Farms at Hanford*, (letter to the President, November 27), U.S. Department of Energy, Richland Operations Office, Richland, Washington.
- Ligotke, M. W., T. R. Clauss, J. L. Huckaby, G. W. Dennis, R. B. Lucke, S. C. Goheen, October 1993, *Aerosol and Vapor Characterization of Tank 241-C-103: Flammability Assessment Sampling System, and Method Validation*, PNL-8875, Pacific Northwest Laboratory, Richland, Washington.
- Michael, D. I., D. Neptune, R. Rytty, P. Black, J. Scott, B. Pulsipher, 1993, *Tank Waste Remediation System Data Quality Objectives Process Guidance: Requirements, Style and Content*, Draft Guidance.
- Osborne, J. W., 1994, *Program Plan for the Resolution of Tank Vapor Issues*, WHC-EP-0562, Revision 1, Westinghouse Hanford Company, Richland, Washington.
- Turner, D. T., *Organic Layer Sampling for SST 241-C-103 Background, and Data Quality Objectives, and Analytical Plant*, PNL-8811, Pacific Northwest Laboratory, Richland, Washington.
- Wood, S. A., 1993, *Gas Space Analysis of Tank C-109*, WHC-SD-WM-ER-183, Rev. 0, Westinghouse Hanford Company, Richland, Washington.
- USEPA, 1994, *Guidance for the Data Quality Objectives Process*, EPA QA/G4, Final, September 1994, United States Environmental Protection Agency, Washington, D.C.
- WHC, 1994, *Tank 241-C-103 Vapor and Gas Sampling Data Quality Objective*, WHC-EP-0774, Westinghouse Hanford Company, Richland, Washington.



Department of Energy

Richland Field Office
P.O. Box 550
Richland, Washington 99352

SEP 29 1995

95-TSD-130

The Honorable John T. Conway
Chairman
Defense Nuclear Facilities Safety Board
Suite 700
625 Indiana Avenue, NW
Washington, D.C. 20004

Dear Mr. Conway:

COMPLETION OF REPORTING COMMITMENTS TO THE DEFENSE NUCLEAR FACILITY SAFETY BOARD (DNFSB) UNDER RECOMMENDATION 90-7

This letter is to advise the Defense Nuclear Facility Safety Board (DNFSB) that the U. S. Department of Energy, Richland Operations Office (RL), has completed the activities required to close out certain of the identified milestones developed in "Program Plan for Resolution of the Ferrocyanide Waste Tank Safety Issue at the Hanford Site" DOE/RL-94-110, in response to DNFSB Recommendation 90-7. The reports attached provide the technical basis for the determination that a particular milestone has been completed. Additional detail concerning each reported activity will be provided in the next quarterly report.

If you have any questions, please contact me on (509) 376-4550.

Sincerely,

A handwritten signature in cursive script that reads "Mary F. Jarvis".

Mary F. Jarvis, Ph.D., Project Director,
Tank Safety Analysis Division

TSD:DHI

Enclosures

cc w/o encls:
T. P. Grumbly, EM-1, HQ
S. P. Cowan, EM-30, HQ
J. V. Antizzo, EM-37, HQ
M. A. Hunemuller, EM-38, HQ
C. O'Dell, EM-37, HQ

1. PNL-10713, "Ferrocyanide Safety Project: Ferrocyanide Aging Studies 0 FY-1995 Annual Report." 3.5.5.1.1.D
2. 9555202, Internal Memo for Milestone T2B-95-118, "Implement Moisture Monitoring for Ferrocyanide". 3.1.5.3.1.B
3. WHC, 1995, "Tank Characterization Report for Single-Shell Tank 241-C-111", WHC-SD-WM-ER-481, Rev. 0-B. 3.4.5.1.1.C (1 OF 4)
4. WHC, 1995, "Tank Characterization Report for Single-Shell Tank 241-TY-104", WHC-SD-WM-ER-481, Rev. 0-A. 3.4.5.1.1.C (1 OF 4)
5. WHC, 1995, "The Contact-Temperature Ignition (CTI) Criteria for Propagating Chemical Reactions Including the Effect of Moisture and Application to Hanford Waste", WHC-SD-WM-ER-496, Rev. 0, Richland, Washington. 3.5.5.2.1.C
6. Bryan S. A., K. H. Pool, S. L. Bryan, B. D. Lemer, G. M. Mong, G. F. Schiefelbein, R. L. Sell, L. M. P. Thomas, F. V. Hoopes, S. V. Forbes, 1995, "Ferrocyanide Safety Program Cyanide Speciation Studies Final Report", PNL-10696, Prepared for the U. S. Department of Energy, Pacific Northwest Laboratory, Operated for the U. S. Department of Energy by Battelle Memorial Institute. 3.5.5.1.1.B
7. Scheele R. D., 1995, "Ferrocyanide Safety Project: Comparison of Actual and Simulated Ferrocyanide Waste Properties", PNL-10175, Prepared for the U. S. Department of Energy, Pacific Northwest Laboratory, Richland, Washington. 3.5.5.1.1.F
8. Simmons C. S., 1995, "Modeling Water Retention of Tank Waste", PNL-10831, Prepared for the U. S. Department of Energy, Pacific Northwest Laboratory Operated for the U. S. Department of Energy by Battelle Memorial Institute. 3.5.5.1.1.A
9. Burgeson I. E., S. A. Bryan, 1995, "Ferrocyanide Tank Safety Program: Cesium Uptake Capacity of Simulated Ferrocyanide Tank Waste: Final Report", PNL-10697, Pacific Northwest Laboratory Operated for the U. S. Department of Energy by Battelle Memorial Institute. 3.5.5.1.1.C
10. WHC, 1995, "Remote Characterization of Mixed Waste by Infrared Spectroscopy", WHC-SD-WM-RPT-192, Rev. 0, Management and Operations Contractor for the U. S. Department of Energy, Richland Washington. 3.4.5.3.1.A
11. Callaway W. S., 1995, "Scanning Electron Microscopic Analyses of Ferrocyanide Tank Wastes for the Ferrocyanide Safety Program, Fiscal Year 1995 Report", WHC-SD-EM-RPT-194, Rev. 0, Hanford Operations and Engineering contractor for the U. S. Department of Energy.
12. WHC, 1995, "Summary of FY 1995 NIR Moisture Measurement, Development and Implementation Activities", Management Operations Contractor for the U. S. Department of Energy. 3.4.5.3.1.A

13. WHC, 1995, "Ferrocyanide Safety Program: Final Report on Adiabatic, Calorimetry and Tube Propagation Tests with Synthetic Ferrocyamide Materials", WHC-SD-WM-ER-519, Rev. 0, Management and Operations Contractor for the U. S. Department of Energy. 3.5.5.2.1.B
14. WHC, 1995, "Ferrocyanide Safety Program: Analysis of Postulated Energetic Reactions and Resultant Aerosol Generation in Hanford Site Waste Tanks", WHC-EP-0876, Management and Operations Contractor for the U. S. Department of Energy, Richland, Washington. 3.5.5.2.1.A



Department of Energy

Richland Field Office

P.O. Box 550

Richland, Washington 99352

SEP 29 1995

95-TOP-165

The Honorable John T. Conway
Chairman
Defense Nuclear Facilities Safety Board
Suite 700
625 Indiana Ave, NW
Washington, D.C. 20004

Dear Mr. Conway:

TRANSMITTAL DOCUMENTATION FOR CLOSURE OF DEFENSE NUCLEAR FACILITY SAFETY BOARD
(DNFSB) 93-5 COMMITMENT 1.21.07

This letter is to advise the DNFSB that the U.S. Department of Energy, Richland Operations Office (RL) has accepted the Waste Compatibility Data Quality Objective (DQO). The document transmitted herein closes the following DNFSB 93-5 commitment:

- 1.21.07, Waste Compatibility DQO Report, (Attachment 1 Data Quality Objectives For Tank Farms Waste Compatibility Program.)

This DQO is approved for use at this time. This DQO document may change as changing operational conditions warrant modification.

If you have any questions, please contact Mr. Ami B. Sidpara, Director, Tank Operations Division on (509) 376-0933.

Sincerely,

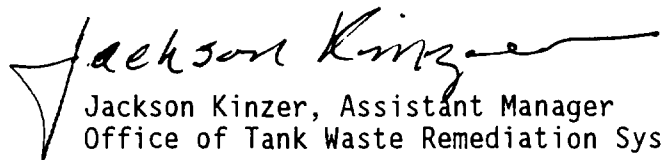
Jackson Kinzer, Assistant Manager
Office of Tank Waste Remediation System

Attachment

cc w/o att:

T. P. Grumbly, EM-1
J. E. Lytle, EM-30
C. O. Dell, EM-36

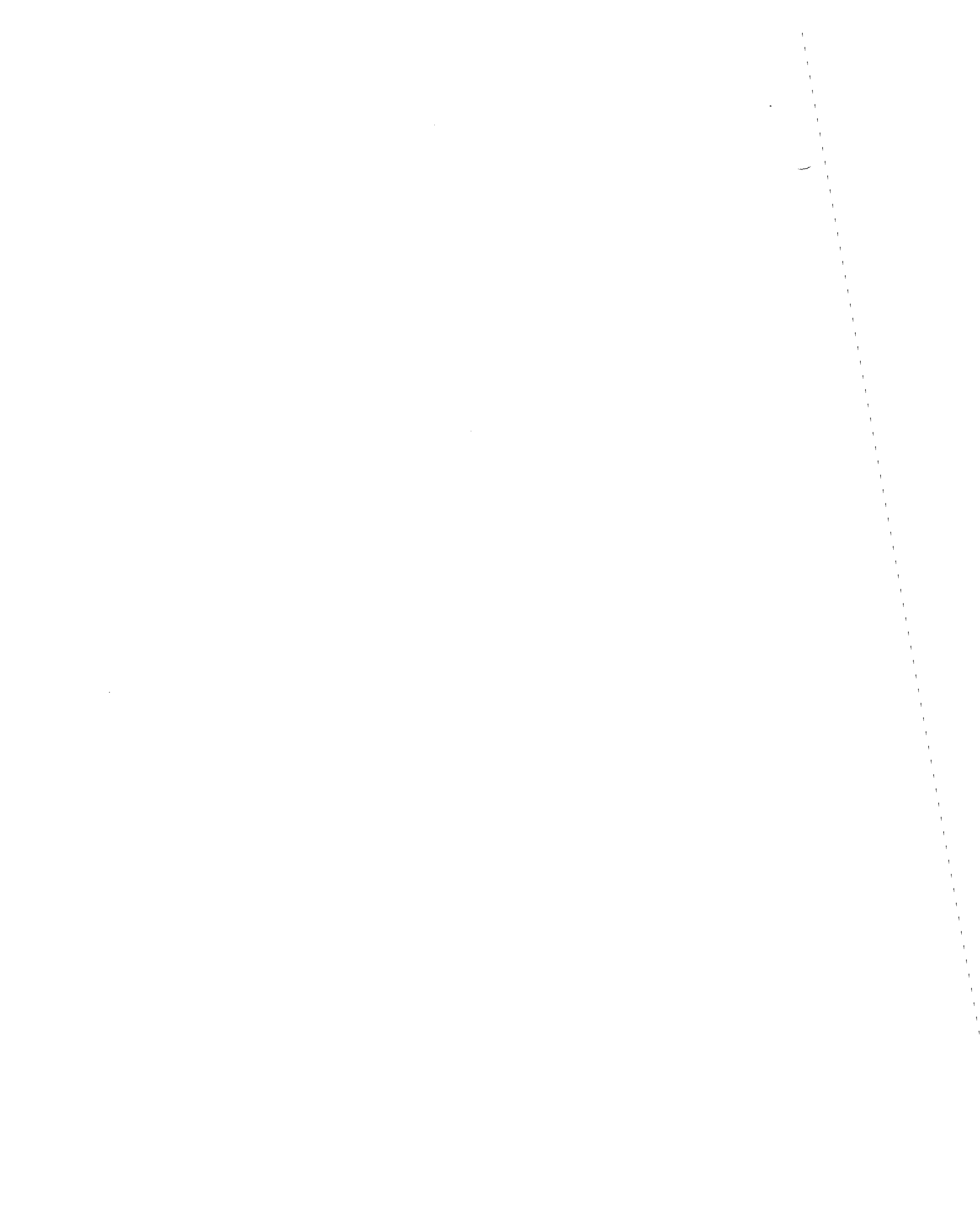

ENGINEERING CHANGE NOTICE

Page 1 of 4

1. ECN **№ 623160**

Proj.
ECN

2. ECN Category (mark one) Supplemental <input type="checkbox"/> Direct Revision <input checked="" type="checkbox"/> Change ECN <input type="checkbox"/> Temporary <input type="checkbox"/> Standby <input type="checkbox"/> Supersedure <input type="checkbox"/> Cancel/Void <input type="checkbox"/>	3. Originator's Name, Organization, MSIN, and Telephone No. K. D. Fowler, 71310, R2-11, 373-5930	3a. USQ Required? <input type="checkbox"/> Yes <input checked="" type="checkbox"/> No	4. Date 4/24/95	
	5. Project Title/No./Work Order No. Compatibility Program/E15758	6. Bldg./Sys./Fac. No. Tank Farms	7. Approval Designator SQ	
	8. Document Numbers Changed by this ECN (includes sheet no. and rev.) SD-WM-DQO-001 Rev. 0 SD-WM-OCD-015 Rev. 0A	9. Related ECN No(s). NA	10. Related PO No. NA	

11a. Modification Work <input type="checkbox"/> Yes (fill out Blk. 11b) <input checked="" type="checkbox"/> No (NA Blks. 11b, 11c, 11d)	11b. Work Package No. NA	11c. Modification Work Complete NA <hr/> Cog. Engineer Signature & Date	11d. Restored to Original Condition (Temp. or Standby ECN only) NA <hr/> Cog. Engineer Signature & Date
-----------------------------------------------------------------------------------------------------------------------------------------------	-----------------------------	-------------------------------------------------------------------------------	---------------------------------------------------------------------------------------------------------------

12. Description of Change
 Total revision for consistency with other updated Tank Farms administrative controls

13a. Justification (mark one)

Criteria Change <input checked="" type="checkbox"/>	Design Improvement <input type="checkbox"/>	Environmental <input type="checkbox"/>	Facility Deactivation <input type="checkbox"/>
As-Found <input type="checkbox"/>	Facilitate Const <input type="checkbox"/>	Const. Error/Omission <input type="checkbox"/>	Design Error/Omission <input type="checkbox"/>

13b. Justification Details
 Review of the compatibility program showed that revision was necessary for compliance with updated CPS and other administrative control documents.

14. Distribution (include name, MSIN, and no. of copies) See distribution sheet	RELEASE STAMP OFFICIAL RELEASE 2 BY WHC DATE APR 24 1995 <i>Ste 4</i>
------------------------------------------------------------------------------------	-----------------------------------------------------------------------------------------------------------------------------------------------------------------------

~~ENGINEERING DATA TRANSMITTAL~~
47 4/20/95

Page 1 of 1
1. EDT NO. ~~611640~~

2. To: (Receiving Organization) East Tank Farm Plant Engineering		3. From: (Originating Organization) Waste Tanks Process Engineering		4. Related EDT No.: 611648	
5. Proj./Prog./Dept./Div.: Tank Farm		6. Cog. Engr.: K. D. Fowler		7. Purchase Order No.:	
8. Originator Remarks: Transmitted to document the updated Tank Farm Waste Transfer Compatibility Program					
11. Receiver Remarks:					
9. Equip./Component No.:					
10. System/Bldg./Facility: - Tank Farms					
12. Major Assm. Dwg. No.:					
13. Permit/Permit Application No.:					
14. Required Response Date:					

15. DATA TRANSMITTED					(F)	(G)	(H)	(I)
(A) Item No.	(B) Document/Drawing No.	(C) Sheet No.	(D) Rev. No.	(E) Title or Description of Data Transmitted	Approval Desig- nator	Reason for Trans- mittal	Origina- tor Dispo- sition	Receiv- er Dispo- sition
1	WHC-SD-WM-OCD-015		1	Tank Farm Waste Transfer Compatibility Program	SQ	1,2		

16. KEY		
Approval Designator (F)	Reason for Transmittal (G)	Disposition (H) & (I)
E, S, Q, D or N/A (see WHC-CM-3-5, Sec. 12.7)	1. Approval 2. Release 3. Information 4. Review 5. Post-Review 6. Dist. (Receipt Acknow. Required)	1. Approved 2. Approved w/comment 3. Disapproved w/comment 4. Reviewed no/comment 5. Reviewed w/comment 6. Receipt acknowledged

17. SIGNATURE/DISTRIBUTION (See Approval Designator for required signatures)											
(G)	(H)	(J) Name (K) Signature (L) Date (M) MSIN				(J) Name (K) Signature (L) Date (M) MSIN				(G)	(H)
Reason	Disp.									Reason	Disp.
1	1	Cog. Eng. K. D. Fowler <i>K. D. Fowler</i> 4/20/95 2211									
1	1	Cog. Mgr. W. B. Barton <i>W. B. Barton</i> 4/24/95				S. M. Jones Cog. Eng. <i>S. M. Jones</i> 04-20-95				1	1
1	1	QA T. C. Tribble <i>T. C. Tribble</i> 4/20/95									
1	1	Safety M. N. Islam <i>M. N. Islam</i> 4/20/95									
		Env.									
1	1	R. A. Dodd <i>R. A. Dodd</i> 4/20/95									
1	1	T. S. Veil <i>T. S. Veil</i> 4/20/95									

18. K. D. Fowler <i>K. D. Fowler</i> Signature of EDT Originator Date 4/20/95		19. R. A. Dodd <i>R. A. Dodd</i> Authorized Representative for Receiving Organization Date 4/20/95		20. W. B. Barton <i>W. B. Barton</i> Cognizant Manager Date 4/21/95		21. DOE APPROVAL (if required) Ctrl. No. <input type="checkbox"/> Approved <input type="checkbox"/> Approved w/comments <input type="checkbox"/> Disapproved w/comments	
-------------------------------------------------------------------------------------------	--	----------------------------------------------------------------------------------------------------------------	--	------------------------------------------------------------------------------	--	-------------------------------------------------------------------------------------------------------------------------------------------------------------------------------------	--

~~ENGINEERING DATA TRANSMITTAL~~

27. HAZARDS

2. To: (Receiving Organization) East Tank Farm Plant Engineering		3. From: (Originating Organization) Waste Tanks Process Engineering		4. Related EDT No.: 611649	
5. Proj./Prog./Dept./Div.: Tank Farm		6. Cog. Engr.: K. D. Fowler		7. Purchase Order No.:	
8. Originator Remarks: Transmitted to document the updated Tank Farm Waste Transfer Compatibility Program				9. Equip./Component No.:	
				10. System/Bldg./Facility: Tank Farms	
				11. Receiver Remarks:	
				12. Major Assm. Dwg. No.:	
				13. Permit/Permit Application No.:	
				14. Required Response Date:	

15. DATA TRANSMITTED					(F)	(G)	(H)	(I)
(A) Item No.	(B) Document/Drawing No.	(C) Sheet No.	(D) Rev. No.	(E) Title or Description of Data Transmitted	Approval Designator	Reason for Transmittal	Originator Disposition	Receiver Disposition
1	WHC-SD-WM-DQO-001		1	Data Quality Objectives For Tank Farms Waste Compatibility Program	SQ	1,2		

16. KEY		
Approval Designator (F)	Reason for Transmittal (G)	Disposition (H) & (I)
E, S, O, D or N/A (see WHC-CM-3-5, Sec.12.7)	1. Approval 2. Release 3. Information 4. Review 5. Post-Review 6. Dist. (Receipt Acknow. Required)	1. Approved 2. Approved w/comment 3. Disapproved w/comment 4. Reviewed no/comment 5. Reviewed w/comment 6. Receipt acknowledged

17. SIGNATURE/DISTRIBUTION (See Approval Designator for required signatures)											
(G)	(H)	(J) Name (K) Signature (L) Date (M) MSIN				(J) Name (K) Signature (L) Date (M) MSIN				(G)	(H)
Reason	Disp.									Reason	Disp.
1	/	Cog. Eng. K. D. Fowler <i>[Signature]</i> 4/20/95 102-11									
1	/	Cog. Mgr. W. B. Barton <i>[Signature]</i> 4/24/95				Cog. Eng. J. M. Jones <i>[Signature]</i> 4-20-95				1	1
1	/	QA T. C. Triple <i>[Signature]</i> 4/20/95									
1	/	Safety M. N. Islam <i>[Signature]</i> 4/20/95									
		Env.									
1	/	R. A. Dodd <i>[Signature]</i> 4/20/95									
1	/	T. S. Vail <i>[Signature]</i> 4/20/95									

18. Signature of EDT Originator <i>[Signature]</i> K. D. Fowler Date: 4/20/95		19. Authorized Representative for Receiving Organization <i>[Signature]</i> Date: 4/24/95		20. Cognizant Manager <i>[Signature]</i> W. B. Barton Date: 4/24/95		21. DOE APPROVAL (if required) Ctrl. No. <input type="checkbox"/> Approved <input type="checkbox"/> Approved w/comments <input type="checkbox"/> Disapproved w/comments	
----------------------------------------------------------------------------------------	--	-------------------------------------------------------------------------------------------------	--	------------------------------------------------------------------------------	--	----------------------------------------------------------------------------------------------------------------------------------------------------------------------------------	--

RELEASE AUTHORIZATION

Document Number: WHC-SD-WM-DQO-001, REV 1

Document Title: Data Quality Objectives for Tank Farms Waste Compatibility Program

Release Date: 4/24/95

This document was reviewed following the procedures described in WHC-CM-3-4 and is:

APPROVED FOR PUBLIC RELEASE

WHC Information Release Administration Specialist:

Kara M. Broz

April 24, 1995

TRADEMARK DISCLAIMER. Reference herein to any specific commercial product, process, or service by trade name, trademark, manufacturer, or otherwise, does not necessarily constitute or imply its endorsement, recommendation, or favoring by the United States Government or any agency thereof or its contractors or subcontractors.

This report has been reproduced from the best available copy. Available in paper copy and microfiche. Printed in the United States of America. Available to the U.S. Department of Energy and its contractors from:

U.S. Department of Energy
Office of Scientific and Technical Information (OSTI)
P.O. Box 62
Oak Ridge, TN 37831
Telephone: (615) 576-8401

Available to the public from: U.S. Department of Commerce
National Technical Information Service (NTIS)
5285 Port Royal Road
Springfield, VA 22161
Telephone: (703) 487-4650

SUPPORTING DOCUMENT

1. Total Pages *41*

2. Title

Data Quality Objectives for Tank Farms Waste Compatibility Program

3. Number

WHC-SD-WM-DQO-001

4. Rev No.

1

5. Key Words

Characterization, Compatibility, Criteria, Decision Rules, Double-Shell Tank, Tank Farms, Waste Transfer

6. Author

Name: K. D. Fowler

K. D. Fowler
Signature

Organization/Charge Code 71310 / *N1F6N*
N1208

7. Abstract

Waste compatibility within the Tank Waste Remediation System (TWRS) double-shell tank farms at the Hanford Site is implemented via the *Tank Farms Waste Transfer Compatibility Program*, WHC-SD-WM-OCD-015.

This DQO for waste compatibility includes a statement of the transfer problem(s), identification of safety and operations related decision elements relevant to waste transfers, a list of the data inputs to these decisions, a description of the transfers covered, and quantitative decision rules for the safety decisions.

8. RELEASE STAMP

OFFICIAL RELEASE 2
BY WHC
DATE APR 24 1995
St 4



ACRONYMS

BTU/hr	British thermal units per hour
CC	concentrated complexant waste
CP	concentrated phosphate waste
CPS	Criticality Prevention Specification
DC	dilute complexant waste
DN	dilute non-complexant waste
DOE	United States Department of Energy
DOE-RL	U. S. Department of Energy Richland Operations Field Office
DQO	Data Quality Objectives
DSC	differential scanning calorimetry
DSSF	double-shell slurry feed
DST	double-shell tank
g/gal	grams per gallon
g/L	grams per liter
GEA	gamma energy analysis
HLW	high-level waste
Kg	kilogram
LLW	low-level waste
M	molar
nCi/g	nanocuries per gram
N _{Re}	Reynolds number
NCAW	aging waste from PUREX
OSD	Operating Specification Document
PD	PUREX neutralized cladding removal waste
PT	TRU solids fraction from Plutonium Finishing Plant operations
QA	Quality Assurance
QC	Quality Control
RPD	relative percent difference
SIE	specific ion electrode
SpG	specific gravity
SST	single-shell tank
TGA	Thermo-gravimetric analysis
TOC	total organic carbon
TRU	transuranic

7.0 DQO STEP 7: SAMPLING AND ANALYSIS DESIGN OPTIONS	27
7.1 PRELIMINARY ASSESSMENT OF CRITICALITY DATA	28
7.2 PRELIMINARY ASSESSMENT OF FLAMMABLE GAS ACCUMULATION CRITERION	29
7.3 LABORATORY ANALYSIS OPTIONS	29
7.4 DATA REQUIREMENTS	29
7.4.1 Laboratory Control Standards	32
7.4.2 Precision and Accuracy	32
8.0 REFERENCES	35

CONTENTS

1.0 INTRODUCTION	1
2.0 DQO STEP 1: STATEMENT OF THE PROBLEM	2
2.1 BACKGROUND	2
2.2 PROBLEM STATEMENT	3
2.3 ISSUES RELATED TO WASTE COMPATIBILITY PROBLEMS	3
2.4 GENERAL APPROACH TO ASSESSING WASTE COMPATIBILITY	4
2.5 PRACTICAL CONSTRAINTS FOR THE WASTE COMPATIBILITY PROGRAM	5
3.0 DQO STEP 2: IDENTIFY THE DECISION TO BE MADE	6
3.1 SAFETY CONSIDERATIONS	6
3.2 OPERATIONS CONSIDERATIONS	7
4.0 DQO STEP 3: IDENTIFY INPUTS TO THE DECISION	8
4.1 SAFETY INPUTS	8
4.1.1 Criticality	8
4.1.2 Flammable Gas Accumulation	8
4.1.3 Energetics	9
4.1.4 Corrosion	10
4.1.5 Watch List Tanks	10
4.1.6 Chemical Compatibility	10
4.2 OPERATIONS INPUTS	10
4.2.1 Segregate Waste Types	11
4.2.2 Avoid Exceeding the Heat Generation Rate Limit	11
4.2.3 Determine Pumpability of the Waste	11
4.2.4 Tank Waste Type	12
4.2.5 High Phosphate Waste	12
5.0 DQO STEP 4: DECISION BOUNDARIES	13
6.0 DQO STEPS 5,6: DECISION RULE SUMMARIES AND ERROR CONSEQUENCES	14
6.1 SAFETY DECISION RULES	14
6.1.1 Criticality Decision Rule	14
6.1.2 Flammable Gas Accumulation Decision Rule	18
6.1.3 Energetics Decision Rule	19
6.1.4 Corrosion Decision Rule	21
6.1.5 Watch List Tanks Decision Rule	23
6.1.6 Chemical Compatibility Decision Rule	23
6.2 OPERATIONS DECISION RULES	23
6.2.1 TRU Waste Segregation Rule	23
6.2.2 Heat Generation Rate Rule	24
6.2.3 Complexant Waste Segregation Rule	24
6.2.4 Waste Pumpability Rule	24
6.2.5 Tank Waste Type	24
6.2.6 High Phosphate Waste	25

1.0 INTRODUCTION

The *Tank Farm Waste Transfer Compatibility Program* (Fowler 1995) formalizes the process for assessing waste compatibility for transfers into and within the double-shell tank (DST) system. Data Quality Objectives (DQO) for Tank Farms Waste Transfer Compatibility are described in this document.

This DQO is expected to evolve in accord with the TWRS DQO Strategy (Babad et al. 1994). The retrieval and transfer of wastes stored in the single-shell tanks (SSTs) will require non-routine compatibility decisions to be made. Very little historical data are currently available from which an estimate of the variability of these wastes can be derived. Pertinent estimates of uncertainty (e.g., estimates of the variability of constituents of interest in the wastes, and estimates of the variability and accuracy associated with measuring these constituents) are key inputs to the statistical design of data collection events. Therefore, the first designs generated based on this DQO will need to be based, to some extent, on engineering judgement.

In addition to revising the design for data collection, several of the decision criteria proposed in this report are subject to change given such factors as tank farm policies and an enhanced understanding of waste tank safety issues. As these criteria change, the decision rules in this report, the limits on decision errors and, the design for data collection may also require changes. Therefore, prior to each new data collection effort (for non-routine waste transfers) in support of deciding whether to allow a waste transfer, this DQO will be reviewed and any appropriate changes entertained at that time. If substantial changes are needed, interested stakeholders will be notified. Implications may then be discussed and input incorporated into the revised DQO and corresponding data collection design.

This DQO specifies the data needs for assessing waste transfers. For routine waste streams the use of process control chart techniques (where available) will be adequate to assure reported values are within acceptable decision error tolerances. This is true because these waste streams are dilute and Hanford processing facilities have been shut down. If data are not available for adequately assessing a routine transfer, data generation will be governed by this DQO.

For non-routine (limited historical data available) transfer decisions this DQO will be reviewed, and appropriate action taken. Sampling designs that are expected to meet this DQO will be developed. For situations where there is inadequate data to generate a statistical design based on this DQO, a number of critical assumptions will have to be made in order to proceed. A data quality assessment to confirm data adequacy for decision making will also be necessary. In such situations this DQO will guide the design qualitatively during planning, and will serve as the criteria for a quantitative analysis of data adequacy when data are collected.

2.0 DQO STEP 1: STATEMENT OF THE PROBLEM

2.1 BACKGROUND

The overall problem addressed in this report relates to the potential incompatibility of wastes that either are stored in, or will be received into the Hanford Site double-shell tank (DST) System. The primary goal is to assure that safety and operations problems such as flammable gas accumulation or transfer line plugging do not result from waste transfers in the DST system. Also, every effort will be made to prevent the formation of an unreviewed safety question (USQ) as the result of operating the DST system to receive, process, and store waste.

The current waste segregation philosophy is based on four main categories of waste: transuranic (TRU), complexant, non-complexed low-level waste (LLW), and high-level waste¹ (HLW). This philosophy will aid in maximizing the waste volume reductions which may be achieved and help to minimize final disposal costs. Design of the tank farms compatibility strategy is based on process knowledge and safety considerations. This strategy is summarized by the criteria below.

Criteria addressing regulatory requirements for waste receipt into the DST system are addressed in the Double-Shell Tank Waste Analysis Plan (Mulkey and Jones, 1994).

General criteria for waste transfers:

- 1) Comply with existing requirements and guidelines, which include flow sheets, operating specification document (OSD) limits, operational safety requirements (OSRs), and criticality prevention specifications (CPSs). These guidelines are based on chemical or physical measurements of the waste (e.g., OH^- , NO_3^- , NO_2^- , Pu). Most of the analytical requirements are needed to comply with these guidelines.
- 2) Watch List tanks - In accordance with Public Law 101-510, Section 3137, addition of high-level waste is NOT allowed without approval of the Secretary of Energy (with the exception of small amounts removed and returned to a tank for analysis). Transfers involving a Watch List tank shall have been reviewed prior to acceptance, to assure the potential for release of high-level waste is not increased.

¹ High-Level Waste is defined as the highly radioactive material that results from the reprocessing of spent nuclear fuel, including liquid waste produced directly in reprocessing and any solid waste derived from the liquid, that contains a combination of transuranic waste and fission products in concentrations requiring permanent isolation. (DOE 1988, Attachment 2)

Specific technical criteria (based on safety concerns and operational "rules of thumb"):

- 1) Chelating organic water solutions are segregated as complexant to keep waste dilute enough to prevent slurry formation (operations).
- 2) Waste that may contact a TRU solid layer must not dissolve the TRU (operations - in accordance with DOE Order 5820.2A).
- 3) Avoid mixing high phosphate waste solutions with high sodium salt waste solutions which causes precipitation of Na_3PO_4 (operations).
- 4) Waste exhibiting exotherms > endotherms based on thermal analysis should be segregated from all other wastes (safety).

2.2 PROBLEM STATEMENT

The purpose of the Waste Transfer Compatibility Program is to establish specifications for waste transfers into and within the DST system to prevent safety or operational problems such as flammable gas accumulation, tank corrosion and transfer line plugging. Many of the guidelines are based on process knowledge or historical information about the causes of compatibility problems.

This DQO establishes data requirements for waste transfer compatibility decisions and documents the types and amount of data required by the compatibility program. In conjunction with the Tank Farms Waste Transfer Compatibility Program (Fowler 1995) and the DST Waste Analysis Plan (Mulkey and Jones 1994), it provides a comprehensive plan to evaluate waste transfers.

2.3 ISSUES RELATED TO WASTE COMPATIBILITY PROBLEMS

For the DST system, there are two main issues relating to waste compatibility. These issues, given below, have overlapping data requirements.

- 1) Assurance that no safety problems are created as a result of commingling wastes under interim storage.
- 2) Assurance of continued operability during waste transfer and waste concentration/minimization (e.g., do not plug transfer or process lines, trap flammable gas, promote exothermic reactions, corrode lines or double-shell tanks, or thermally stress double-shell tanks).

2.4 GENERAL APPROACH TO ASSESSING WASTE COMPATIBILITY

The approach to evaluating waste compatibility for the DST system has been developed based on engineering process knowledge and observations of operational problems. The approach is described in the latest revision of the Tank Farms Waste Transfer Compatibility Program (Fowler 1995). Guidelines are given for assessing both non-routine and routine transfers into and within the tank farms.

Certain additions to waste tanks are unlikely to cause any waste compatibility problems. This type of addition may occur on a regular basis, thus, conducting detailed waste compatibility assessments each time is neither economically nor technically justified.

Water used to pressure test waste transfer pipelines is one example of such an addition. The water used in a pressure test drains back into DSTs where it mixes with the stored waste. Because all DST wastes are aqueous solutions and slurries of inorganic salts contaminated with minor amounts of radionuclides and organic salts, water additions serve only to dilute the waste and, in most cases, reduce interactions between compounds in the waste.

Therefore, the following types of waste transfers in the tank farms are exempt from waste compatibility assessments:

- Potentially contaminated water (e.g., cooling water, rain water, snow melt, pipeline flush water, pipeline pressure test water, deentrainer flush water, airlift circulator flush water) with no chemical reagents added except for those required for tank corrosion control (i.e., sodium hydroxide and sodium nitrite).
- Dilute, organic-free waste containing any of the major inorganic salts (i.e., sodium aluminate, sodium nitrate, sodium nitrite, sodium carbonate, sodium sulfate, sodium phosphate, sodium fluoride, and sodium chloride), sodium hydroxide, trace metals, and radionuclides commonly found in Hanford Site wastes at concentrations that would form a waste mixture free of precipitation (i.e., < 1 vol. % solids) when blended with another waste.²
- Small volumes (i.e., 0.1 % of the existing receiver tank volume or 500 gallons, whichever is less) of essentially organic-free waste containing any of the major inorganic salts, trace metals, or radionuclides regardless of precipitation.

Although these waste transfers are exempt from detailed waste compatibility assessments, these transfers must comply with safety decision rules and with the criteria given in the DST Waste Analysis Plan (Mulkey and Jones 1994). To

² Note decision rule 6.2.6 for mixing of high phosphate wastes.

assure compliance with safety decision rules, exempt transfers also require concurrence of Waste Tanks Process Engineering and Environmental Engineering.

2.5 PRACTICAL CONSTRAINTS FOR THE WASTE COMPATIBILITY PROGRAM

Sampling designs to determine waste compatibility are constrained by the following factors:

- 1) The number of risers available for sampling in a given single-shell or double-shell tank are limited. Sampling of other waste sources may be limited by physical factors.
- 2) Sampling of the liquid wastes stored in single-shell tanks may be limited to surface pools below risers and/or liquid in saltwell screens, where available. Most of the liquid in SSTs is interstitial in the saltcake and sludges deposited in these tanks.
- 3) The change of the Hanford Site mission from production and separation of nuclear materials to environmental remediation and restoration has virtually eliminated the generation of large volumes of radioactive chemical wastes. Shipments of routine wastes from generators have become more infrequent and more dilute. Smaller volumes, lower chemical concentrations, and higher weight fractions of water are factors that reduce the need for rigorous sampling designs for assessing waste compatibility.

3.0 DQO STEP 2: IDENTIFY THE DECISION TO BE MADE

There are five possible actions that may be taken based on compatibility assessments:

- 1) Transfer waste to designated (selected) double-shell receiver tank(s)
- 2) Transfer waste to 242-A Evaporator for concentration
- 3) Commingle³ wastes which are already within the double-shell tank system
- 4) Ship waste to some other treatment, storage and disposal facility
- 5) Store waste where it is until pretreatment and waste disposal facilities become operational.

Safety and operations considerations identified below will help determine the action which may be taken without creating an USQ or operational problems. These will also help to:

- prevent actions that will violate OSR or OSD limits.
- prevent actions that will lead to plugging of process lines and equipment.
- prevent actions that will desegregate TRU waste to the extent possible.

3.1 SAFETY CONSIDERATIONS

Safety considerations help determine whether wastes may be transferred, combined, and stored in double-shell tanks (DSTs) without causing any safety problems. The safety considerations will encompass the potential of the following kinds of safety problems:

- criticality,
- flammable gas generation and accumulation,
- energetics⁴,
- corrosion and leakage, and
- unwanted chemical reactions

³ For purposes of this DQO commingled waste is defined as the mixture of transfer source waste and the waste already in the receiving DST.

⁴ Energetics refers to the ability of a waste to sustain a self propagating exothermic reaction. This is generally measured via thermal analysis (DSC and TGA).

Administrative controls preclude opening risers or conducting other intrusive activities in a tank actively involved in a waste transfer. There are no avenues for fugitive emissions to enter the work space above a tank during a transfer operation.

Other specific issues such as high organic and ferrocyanide Watch List tanks have not been singled out in this DQO for the following reasons:

- The high water content of the wastes stored in the DSTs precludes the addition of these tanks to either the organic or the ferrocyanide Watch List. For details see Babad and Turner 1993 for organic tanks, and Postma et al. 1994 for ferrocyanide tanks.
- Adherence to the energetics decision rule (Section 6.1.3) will assure that wastes capable of sustaining a propagating reaction, regardless of the fuel present, will not be accepted unwittingly into the DST system.

3.2 OPERATIONS CONSIDERATIONS

Operations considerations help determine whether wastes may be transferred/combined without exceeding the physical constraints of the transfer piping and tanks in the DST systems. Operations considerations may also address the interface with the 242-A Evaporator, and interim storage.

The operations considerations address the following operational concerns:

- plugged pipelines and equipment (unanticipated precipitation).
- TRU segregation (the basic waste segregation philosophy).
- complexant waste segregation (pipeline or evaporator plugging).
- heat load limits on receiving tank (tank farm ventilation capacity issue).

Waste segregation will help to assure waste volume minimization is not adversely affected by waste transfers. It will also help to prevent increased costs for final waste disposal.

4.0 DQO STEP 3: IDENTIFY INPUTS TO THE DECISION

Decision inputs comprise the tank information and analytical data needed to address each safety and operations consideration to assure transfers will be in compliance with the compatibility program criteria (Section 2.0).

4.1 SAFETY INPUTS

The safety inputs are used in determination of criticality, flammable gas accumulation, energetics, corrosion, and chemical reactivity rule compliance. The decision rules, summarized in Section 6.0, are based on OSDs, CPSs, and on engineering judgement.

4.1.1 Criticality

Data which are needed to evaluate criticality safety include fissionable material concentration (Pu equivalent), and, in some cases, volume percent solids. In some instances, an estimation of solids density may be needed for comparison of criticality limits given in g/L with measurable quantities such as $\mu\text{Ci/L}$ or $\mu\text{g/g}$.

Note: For purposes of criticality control, one gram of Pu is treated as one gram of ^{239}Pu . For the most part, waste generators need only consider the $^{239,240}\text{Pu}$ concentration when determining Pu equivalent concentration mass. Under certain circumstances, other fissionable materials will have to be measured. These materials include ^{235}U , ^{235}U , ^{241}Pu , and (if present in sufficient quantities) ^{237}Np , ^{238}Pu , and ^{241}Am . Treatment of these materials on a Pu equivalent basis is defined in Chapter 2 of the Nuclear Criticality Safety Manual, WHC-CM-4-29 (WHC 1994d).

4.1.2 Flammable Gas Accumulation (with cyclic release), where accumulation is defined as generation and retention

Specific gravity (SpG) of the waste is currently used for determination of the potential to cause an accumulation of flammable gases. The generation of hydrogen or any other flammable gas does not by itself pose a safety problem. Safety becomes a concern when flammable gases accumulate to a concentration above their lower flammability limit (LFL).

Specific gravity was determined to be an indicator for flammable gas accumulation since the six largest average specific gravities for the DSTs were from the six DSTs currently on the Watch List. The limiting SpG value is between 1.43 (the smallest SpG for a Watch List tank) and 1.40 (the largest Spg for a non-Watch List tank).

A statistical analysis of available SpG data from seven DSTs was performed to estimate the variability associated with the average SpG for a DST. Each tank was considered individually. The variability estimates were then used to calculate one-sided 95% confidence intervals for tank 105-AN (the flammable gas Watch List DST with the smallest SpG). For six of the seven variability estimates (85%) the lower limit of the one-sided 95% confidence interval was greater than 1.41. These results provide evidence that 1.41 is an acceptable threshold for accumulation of flammable gas. The variability estimate from tank 105-AP, a heterogeneous tank, was one of the six estimates which provided a lower limit greater than 1.41.

The suitability of using SpG to determine gas accumulation potential has been questioned, because a direct correlation between SpG and gas accumulation has not been established. However, the method has been evaluated and there is evidence that SpG is an appropriate limiting factor for prevention of forming flammable gas Watch List tanks (Reynolds 1994). Other methods of gas accumulation potential are being investigated.

4.1.3 Energetics (comparison of exotherms to endotherms)

Data needs include differential scanning calorimetry (DSC) measurements and thermo-gravimetric analysis (TGA) augmented, when necessary, by adiabatic calorimetry; and identification of the presence of separable organic.

The DSTs are a "wet" system. The estimated water content of all the tanks when taken together is roughly 52 wt% (Delegard et al 1993). For the most part, the tank inventory can be considered to be an alkaline aqueous mixture of water-soluble sodium salts (hydroxide, nitrate, nitrite, aluminate, carbonate, phosphate, chloride, and fluoride). Together with water, these salts make up approximately 98 wt% of the total double-shell tank contents. Of the remaining 2 wt%, chemically reactive species of organic carbon and ferrocyanide account for only approximately 30 % (i.e., 0.6 wt% of the total tank inventory).

The components necessary to oxidize fuel are generally present in tank waste and incoming waste streams. Should the temperature rise enough to dry out the waste and initiate a chemical reaction (ca 200 °C), an in-tank reaction could potentially occur. Consequently, evaluation of compliance with the energetics decision rule can be determined by analyzing the waste streams separately.

Because of the high wt% water in the DSTs, the energetics decision rule (Section 6.1.3) will serve mainly to screen waste transfers for an exceptional batch. The exotherm/endothrm ratio is expected to be much less than 1 for virtually all wastes transferred. When the endotherm is greater, a propagating chemical reaction will be inhibited. When large endotherms from the heating of water and phase changes exist, the energy available for heating the waste is greatly diminished and self-heating is prevented.

4.1.4 Corrosion

Waste composition is controlled to keep corrosion rates below 1 mil per year and to inhibit stress corrosion cracking. Data needs for determination of corrosion and leakage potential include hydroxide concentration, nitrate concentration, nitrite concentration, and temperature.

Chloride concentration limits are placed on waste shipments received at the 204-AR Facility to inhibit corrosion of the stainless steel transfer piping within the facility.

Corrosion rules are based on limits specified in the Operating Specification Documents for Tank Farms (WHC 1994a, and WHC 1994e).

4.1.5 Watch List Tanks

In accordance with Public Law 101-510, The Wyden Amendment, No high-level waste will be accepted for transfer to a tank identified as a Watch List tank without Department of Energy approval.

Input for this decision rule is the classification of the tank(s) involved in the transfer. If no Watch List tank is involved in the transfer, then the transfer is in compliance with this rule.

4.1.6 Chemical Compatibility

Input for determining chemical compatibility will consist of the reactivity group number of the source waste. This is to be provided by the waste generator on a waste profile sheet in accordance with the WAP (Mulkey and Jones 1994).

4.2 OPERATIONS INPUTS

Operations inputs are based on the waste segregation policy, avoiding excess heat generation in the tanks, and ensuring pumpability of the source waste to the receiving tank. These inputs will help to assure continued operability of the tank farms.

4.2.1 Segregate Waste Types (TRU from non-TRU waste, complexant from non-complexant waste)

Waste with TRU (e.g., [²³⁹Pu],[²⁴¹Am]) above 100 nCi/g is classified as TRU waste.

Total organic carbon (TOC) concentration is often used to classify a waste as complexant. Concentrations of NO_2^- , NO_3^- , CO_3^{2-} , SO_4^{2-} , PO_4^{3-} , Al^{+3} , OH^{-1} , F^- , and TOC are needed to run the "PREDICT" model for the evaporator (Allison 1984). The PREDICT model for the evaporator (Allison 1984) is generally used to determine [TOC] at double-shell slurry feed (DSSF)⁵ concentration for waste streams containing major inorganic salts (i.e., sodium aluminate, sodium nitrate, sodium nitrite, sodium carbonate, sodium sulfate, sodium phosphate, sodium fluoride) and sodium hydroxide.

A more definitive method of determining whether a stream should be classified as complexant waste is to perform a boildown of the waste in the laboratory. A rapid viscosity increase upon crystallization or the formation of small non-settling crystals indicates that the waste stream is indeed complexant.

4.2.2 Avoid Exceeding the Heat Generation Rate Limit

The heat generation rate is usually estimated based on the mean ⁹⁰Sr, and ¹³⁷Cs concentrations. These are generally determined using beta counting and gamma energy analysis (GEA) respectively.

4.2.3 Determine Pumpability of the Waste (during transfer)

Pumpability of the source waste is estimated by determining the Reynolds number for the transfer system. Data needs for calculating the Reynolds number are density of the waste, viscosity of the waste, pipe diameter and pump velocity (flow rate). Although new data will not necessarily be needed, these are critical inputs.

Volume percent solids (measured and/or estimated) and the cooling curve verification of precipitating solids as a function of temperature may also be used to aid in the determination of waste pumpability.

⁵ DSSF is waste concentrated to the point just prior to reaching the sodium aluminate saturation boundary in the evaporator without exceeding receiver tank composition limits.

4.2.4 Tank Waste Type

The input for waste type is the DST waste classification. Wastes in the DSTs are classified as:

DN	dilute non-complexant waste
DSSF	double-shell slurry feed
DC	dilute complexant waste
CC	concentrated complexant waste
PD	PUREX neutralized cladding removal waste
PT	TRU solids fraction from PFP Plant operations
NCAW	aging waste from PUREX
CP	concentrated phosphate waste

4.2.5 High Phosphate Waste

The inputs for phosphate waste determination is the mean phosphate (PO_4^{-3}) concentration of the source waste, and sodium concentration or source of the waste in the receiver tank(s).

5.0 DQO STEP 4: DECISION BOUNDARIES

The decision rules apply to both routine and non-routine transfers into and within the DST system. For the purposes of this DQO, The DST system is defined as the 28 DSTs, double contained receiver tanks (DCRT) and associated piping. The operations encompassed by the decision rules include:

- 1) Transferring or combining wastes within the DST system tanks,
- 2) transferring waste from the evaporator to the tanks, and
- 3) acceptance of waste transfers from outside of the DST system.

For routine transfers into the tank farms from waste generators, the source is sampled and a decision generally is based on the safety decision rules only. For non-routine transfers, the source, and in some cases the receiver tank(s), is sampled and a decision is based on both the safety and operational decision rules. Exempt non-routine wastes (Fowler 1995, Section 1.2) must comply with the safety decision rules, but may not require sampling.

An important part of tank farm operations is use of the evaporator to reduce waste volumes. The evaporator may be used to process routine and non-routine waste sources, including the saltwell liquids from SST stabilization. The waste compatibility program, especially the limit for the flammable gas accumulation safety decision rule, will affect the volume reduction achieved by the evaporator.

6.0 DQO STEPS 5,6: DECISION RULE SUMMARIES AND ERROR CONSEQUENCES

Decision rules are designed to address safety and operations decisions to assure compliance with the compatibility program criteria (Section 2.0). This section provides a summary of the decision rules for waste transfer and descriptions of error consequences.

For complete implementation of the safety and operations decision rules see the Tank Farm Waste Transfer Compatibility Program (Fowler 1995, Sections 3.1 and 3.2).

6.1 SAFETY DECISION RULES

The chemical and physical data needed for the safety decision rules are summarized in Table 6-1 at the end of Section 6.

6.1.1 Criticality Decision Rule

Criticality control in the double-shell tanks is achieved by conducting operations in compliance with criticality prevention specifications (CPS) (Vail 1994).

Criticality prevention limits have been reproduced here in the criticality decision rule for use in establishing data quality needs. Additional controlling factors contained in the CPS must be complied with when transferring waste. Criticality limits for DSTs and associated equipment can be found in the CPS (Vail 1994). The CPS remains the governing document for criticality prevention.

Criticality Prevention Limits

In general, for receiver tanks:

When the tank plutonium (Pu) inventory⁶, after transfer, is less than 10 Kg, the following limits may be used.

1. Transfer may be made without consideration of the solids content provided at least one of the following conditions is met:
 - Total Pu in the transfer < 15 g.
 - Pu concentration in source waste < 0.013 g/L (0.05 g/gal).

⁶ Pu inventory is calculated using Pu equivalents as defined in WHC, 1994d.

- An air lift circulator is operating in the receiver tank and the transfer contains ≤ 200 g Pu.
 - The transfer is made through a slurry distributor and the total Pu added to the waste at any single position does not exceed 200 g.
2. If at least one of the requirements above is not met, transfers may be made in accordance with the requirements for tanks containing > 10 Kg Pu (below).

When the Pu inventory, after transfer, is equal to or greater than 10 Kg, the solids/Pu mass ratio for the tank contents shall be shown to be at least 1,000 before additional Pu may be added. The ratio is an average value determined by dividing the total solids mass by the total Pu mass.

Also, for transfers to a DST, further limits shall apply depending on one of the following:

- The solids/Pu mass ratio for transferred waste and for waste already in the receiver tank
- Pu inventory and concentration of the incoming waste
- Whether Cadmium (Cd) may be added to the incoming waste

If measurement of the waste to be transferred indicates that the Pu equivalent concentration is within criticality prevention limits, the transfer may be allowed. Otherwise, the transfer may occur if (after re-sampling) the mean of the new data is within the limits. If the mean of the re-sampling data exceeds CPS limits the transfer will not be allowed.

Consequences of Decision Errors:

- a) A FALSE POSITIVE will have occurred if the true Pu equivalent concentration is within CPS limits, but the measured value exceeds limits for criticality prevention.

A false positive would delay a transfer that is safe from a criticality perspective. No impact would exist on the TWRS program if the waste generator resolved the false positive error when re-sampling to verify the initial value. However, such an error could have a small impact on tank farms if the generator chose to dilute the waste based on the initial erroneous value. The dilution material would require chemical additions to meet corrosion control specifications and would require more tank space. No impact would occur if the generator were to use wastes otherwise planned to be shipped to the tank farms as the dilution material.

An additional impact of diluting the waste batch without verifying the true concentration would be overstating the receiver tank fissile material inventory. None of the potential impacts are considered to be significant in light of the shutdown of Hanford Site chemical processing facilities. With the termination of nuclear materials production on site, processing large quantities of fissile material where losses to the tank farm could be significant are not anticipated.

Transfers from most waste generators have become less frequent and more dilute with fissile material concentrations at contaminant levels. Because of changes in Hanford Site operations, the current inventory of fissile materials stored in DSTs is not expected to change appreciably or to become a limiting factor for the receipt of routine waste transfers into any of the tanks.

- b) A FALSE NEGATIVE will have occurred if the true Pu equivalent concentration exceeds criticality prevention limits but the measured value is within the limits.

A false negative would allow a transfer that is potentially unsafe from a criticality perspective. Criticality prevention is based on the double contingency principle, where a system is never allowed to operate where fewer than two unlikely, independent, and concurrent changes or contingencies, if they were to occur, could lead to a possible criticality. This principle leads to an implicit margin of safety in each limiting value. A factor of three is a typical margin of safety applied to criticality assessment.

An important consideration in criticality assessments is that a mass of ²³⁹Pu that is supercritical in a waste generators holding tank (ca 19,000 L {5,000 gal}) will be subcritical in a DST (4.3×10^6 L {1,140,000 gal}). Because of the dispersion that would occur as the waste entered, the mass required for criticality in a DST is much larger. Therefore, operational, criticality assessments used by the waste generators should be more stringent than those required for routine waste compatibility assessments.

These conclusions assume that the fissile material concentration is uniform throughout the settled solids bed in a DST. If the fissile material were more concentrated in localized regions of the tank, the possibility of a criticality occurring might be greater. Criticality safety is achieved by controlling the Pu equivalent concentration in each DST. This limits the fissile mass available and requires a large concentration factor before safety is jeopardized.

- c) RELATIVE CONSEQUENCES OF FALSE POSITIVE AND FALSE NEGATIVE ERRORS: False positive readings may be corrected via re-sampling and analysis. There is much more concern with false negative errors.

Decision error tolerances indicate the degree to which decision makers are comfortable accepting false negative errors. For most routine waste transfers, a 50% probability of making a false negative error when the true value of the Pu concentration is at the criticality prevention limit is acceptable. This error acceptance reflects the safety margin that is built into the limit.

If the measured concentration is within the limit and, hence, transfer is allowed 50% of the time when the true concentration equals the limit, we feel confident that we will not create a criticality problem because of our safety margins. This seemingly high error tolerance for routine transfers is acceptable because the Pu concentrations of the incoming waste streams are expected to be far below the limit.

A higher confidence (i.e. 95% or greater) is desired when the true Pu concentration exceeds the criticality prevention limit by a factor of three (i.e., the probability of making a false negative error is $\leq 5\%$). A decision maker would want to be sure of determining the true concentration, and hence, not accept a transfer when the true concentration exceeds the limit so greatly. This is because the built in safety margins may no longer be relied upon.

Availability of Data:

There is abundant historical data for the routine transfers. Non-routine transfers, by definition, do not have a historical database. Historical estimates of fissile material laboratory measurement precision and accuracy will be used to evaluate the achieved decision error rates. Specifically, it will be assumed that the waste is homogeneous, which means that all uncertainty in the characterization of the waste is caused by measurement error.

Most waste generators that routinely send waste to tank farms collect the waste in agitated tanks as an acid. Because the fissile material is soluble in an acidic solution, agitating a waste batch ensures homogeneity when sampling for fissile material concentration. Once neutralized, the bulk of fissile material precipitates and settles in the solids layer following transfer to a DST. Given the high alkalinity of DST wastes, only residual levels of fissile materials remain in the supernate⁷ and, therefore, may be considered homogeneous for all practical purposes.

Transfers involving precipitated fissile material will require an assessment of the tank(s) Pu inventory to assure compliance with the CPS.

⁷ Assumes that complexing agents are not present.

6.1.2 Flammable Gas Accumulation Decision Rule

- a) If the specific gravity (SpG) of the source is < 1.3 the transfer may be allowed.⁸
- b) If the weighted mean SpG of the commingled waste ≤ 1.41 the transfer may be allowed. If the weighted mean SpG > 1.41 , evaluate the potential for flammable gas accumulation in the commingled waste.

The premise of this approach is that we can use SpG of the source and receiving wastes to identify transfers that may lead to flammable gas accumulation.

If the action level of 1.41 SpG is too low, the consequence will be not allowing transfers that do not pose a safety problem or not operating the evaporator to yield a higher waste volume reduction (wastes stored at a lower SpG than necessary occupy a larger volume). This could result in the construction of more DSTs to meet this increased demand for tank storage space. Waste generating activities such as plant deactivation and SST stabilization could also be delayed. Waste volume projections used to forecast DST requirements assume wastes are concentrated in the evaporator to produce double-shell slurry feed.

A key consideration for future revisions of this DQO report is the validation of this approach through evaluation of historical data and development of other potential indicators of flammable gas accumulation.

Consequences of Decision Errors for 6.1.2(b):

- a) **IMPACT ON THE OPERATION OF THE EVAPORATOR:** The evaporator is capable of generating waste streams having a SpG > 1.45 . For most liquid wastes (potential evaporator feed streams) the SpG < 1.35 . Hence, the waste volume reduction could be impacted by an incorrect specification of the action value for SpG.
- b) **ERRORS PRODUCED BY MEASUREMENT OF SpG:** Errors are expected to be limited by the volume of the source relative to the receiving tank, and by the relatively small uncertainty of SpG measurements. Differences between the measured and "true" weighted mean SpG values for commingled waste are expected to be insignificant (i.e., 1.41 is measured when the true value is 1.42). If SpG measurement error were perceived to be significant, it would recommend that receiving tanks (after transfers have been

⁸ This decision can be made based on process knowledge, rather than through sampling of waste. The basis for the action level waste is that typical double-shell tank high-salt wastes do not yield significant amounts of solids unless SpG > 1.35 . The purpose of this comparison is that most routine transfers involve a dilute source waste, and will pass this simple assessment easily.

completed) be sampled more frequently. Receiving tanks will have a greater impact on the weighted mean SpG, and will usually be more heterogeneous with respect to SpG.

Availability of Data:

Specific gravity data will be reviewed to determine the validity of the 1.41 SpG limit. SpG measurement error is believed to be low, however, laboratory quality control (QC) data relevant to measuring SpG will also be examined to improve the reliability of the limit.

6.1.3 Energetics Decision Rule

If the source waste has no separable organic and if the source and receiving wastes⁹ have endotherms in excess of exotherms evaluated using laboratory thermal analysis (DSC and TGA) conducted up to 500 °C (932 °F), the transfer may be allowed. Otherwise, determine the conditions needed for safely receiving and/or storing the waste.

Consequences of Decision Errors:

- a) A FALSE POSITIVE will have occurred if either a separable organic phase or a net exotherm were reported from the data, but no separable organic actually existed or the "true" exotherm was less than the endotherm.

This type of error would delay the transfer. However, the error would be self-correcting since the evaluation probably would involve re-sampling the waste to verify the initial result and to gain a better understanding of the waste behavior. Cost impacts would occur from completing a safety evaluation before taking further action, re-sampling and analyzing the potentially reactive waste; and performing a detailed technical evaluation.

Observing a separable organic phase when one does not actually exist is unlikely. The specific gravity of the waste sent to tank farms is typically greater than or equal to that of water, whereas typical organic compounds have specific gravities less than water. In a waste sample, light phase organics float and are easily distinguished from the aqueous phase by color differences and the interfacial area between the phases.

Although reporting a net exotherm when one does not exist is possible, this type of decision error is not very plausible given the composition of wastes sent to and stored in DSTs. The DSC method is an interpretive method and requires a trained scientist to perform the analysis. In data interpretation, an exotherm is overstated if the DSC scan does not clearly

⁹ Waste for purposes of the energetics decision rule means a representative sample of the source tank material slated for transfer and a representative sample of the supernate from the receiver tank.

distinguish the exothermic region(s). Although overstating the exotherm could lead to a false positive decision error, this is unlikely because wastes transferred are typically very dilute and because the DSTs are a "wet" storage system.

The water content of the dilute transfers from routine waste generators and of the concentrated wastes produced by the 242-A Evaporator are high (ca 40 - 99 wt %). In general, for DST wastes (even the most reactive types), endotherms are much greater in magnitude than exotherms.

- b) A FALSE NEGATIVE will have occurred if data indicates either no separable organic phase is present or no net exotherm exists, when an organic layer actually exists or the "true" exotherm exceeds the endotherm.

Such an error could allow a transfer to occur that is potentially unsafe. If the error were not discovered, then operations would be allowed to continue without the possible mitigating controls necessary to ensure safe handling and storage of the waste. Discovery of the decision error at a later time (for instance, when sampling the DST before making an inter tank farm transfer) would indicate that an OSD and/or waste compatibility violation may have occurred. The impacts could be removal of the tank from active use (no waste transfers into or out of the tank), and costs associated with performing a safety review and implementing mitigating controls. Also, the energetics decision rule would have to be reviewed and revised to assure accurate evaluation of future transfers.

For a separable organic to become a concern within the DST system, an accumulation must occur over time caused by frequent occurrences of false negative decisions. Because DSTs are actively ventilated, a single error is unlikely to represent a safety concern.

Additionally, the shutdown of production and chemical processing facilities on the Hanford Site has made accumulation of a large inventory of an organic phase in a tank unlikely. Processes that historically experienced significant losses of immiscible organic via entrainment in waste streams discharged to tank farms are no longer operating. The site no longer purchases large quantities of organic compounds for use in processes, thus, the separable organic available to be sent to the tank farms is minimal.

For thermal analysis, making a false negative error is considered highly improbable for the same reasons given above for false positive errors. Trained scientists perform the DSC analyses and the high water content of the tank farm wastes causes endotherms to be greater in magnitude than exotherms. Also, there is a considerable measure of conservatism incorporated in the decision rule by evaluating the DSC up to 500 °C. Temperatures of solutions stored in DSTs are limited to ≤ 113 °C (235 °F) in all farms except 241-AY and 241-AZ Tank Farms, which have a limit of ≤ 127 °C (260 °F). These temperature limits are very conservative relative to the threshold temperature (ca 200 °C {392 °F}) for initiating reactions between fuels and nitrate/nitrite salts in tank wastes.

Availability of Data:

Limited historical energetics data are available for routine transfers. Many of these streams are so dilute that performing a thermal analysis is considered impractical. A random testing of transfers sent to the 204-AR Waste Unloading Facility in 1993 indicated specific gravities of the wastes on the order of 1.01 or less and water contents of up to 99 wt %. Results for some waste batches reported no exotherms determined from DSC analyses. For other batches, N/A (not applicable) was reported for thermal analyses.

6.1.4 Corrosion Decision Rule

Operating specification documents (OSDs) establish waste composition limits in order to control corrosion of the DSTs and support facilities. These limits are specified in (WHC 1994a) for double-shell tanks storing non-aging wastes and in (WHC 1994b) for double contained receiver tanks. The corrosion decision rule given below has been extracted from the OSDs.

NOTE: Square brackets, [], indicate the mean concentration.

1) For Double-Shell Tanks and Double-Contained Receiver Tanks:

- For operating temperatures of receiving tank ≤ 100 °C (212 °F):
 If $[\text{NO}_3^-] \leq 1.0$ M; and 0.01 M \leq $[\text{OH}^-] \leq 5.0$ M; and 0.011 M \leq $[\text{NO}_2^-] \leq 5.5$ M, the transfer may be allowed; OR
 If 1.0 M $<$ $[\text{NO}_3^-] \leq 3.0$ M; and $0.1 \times [\text{NO}_3^-] \leq [\text{OH}^-] < 10.0$ M; and $[\text{OH}^-] + [\text{NO}_2^-] \geq 0.4 \times [\text{NO}_3^-]$, the transfer may be allowed; OR
 If $[\text{NO}_3^-] > 3.0$ M; and 0.3 M \leq $[\text{OH}^-] < 10.0$ M; and $[\text{OH}^-] + [\text{NO}_2^-] \geq 1.2$ M; and $[\text{NO}_3^-] \leq 5.5$ M, the transfer may be allowed.

OR

- For operating temperatures of receiving tank < 75 °C (167 °F):
 If $[\text{NO}_3^-] \leq 1.0$ M; and 0.01 M \leq $[\text{OH}^-] \leq 8.0$ M; and 0.011 M \leq $[\text{NO}_2^-] \leq 5.5$ M, the transfer may be allowed.

OR

- For normal operating temperature of receiving tank > 100 °C (212 °F), allow the transfer if the above concentration limits are met except that $[\text{OH}^-] < 4.0$ M in all cases.

If the waste does not meet these conditions, it must be brought into compliance during transfer through the 204-AR Waste Unloading Facility OR it must be verified, prior to transfer, that composition limits in the receiving tank will not be violated.¹⁰

2) For the 204-AR Waste Unloading Facility:

- For waste shipments received by rail tank car:
If $7 < \text{pH} < 14$ or equivalently ($10^{-7} \text{ M} < [\text{OH}^-] < 0.1 \text{ M}$); **and**
 $[\text{Cl}^-] < 0.01 \text{ M}$, allow receipt of the waste into the facility.

OR

- For waste shipments received by tank trailer:
If $7 < \text{pH} < 14$ or equivalently ($10^{-7} \text{ M} < [\text{OH}^-] < 0.1 \text{ M}$); **and**
 $[\text{Cl}^-] < 0.035 \text{ M}$, allow receipt of the waste into the facility.

Aging wastes, which are currently stored in the 241-AZ tanks, have waste composition limits that are somewhat different than those covered in the corrosion decision rule developed in this section (see WHC 1994c). A corrosion decision rule has not been developed for aging waste tanks because aging wastes are no longer generated with the permanent shutdown of the PUREX Plant.

Reasons Why Decision Errors Have Minimal Consequences:

- a) VOLUME OF SOURCE RELATIVE TO RECEIVING TANK: The effect of incorrectly determining corrosivity is bounded by the relatively small volume of source waste compared to the waste volume in the receiver tank.
- b) HYDROXIDE AND NITRITE LIMITS ARE BASED ON CONSERVATIVE TOLERANCE LIMITS: The goals are to limit general corrosion of tank shells to less than 1 mil per year and to inhibit stress corrosion cracking. The tolerance limits for $[\text{OH}^-]$ and $[\text{NO}_2^-]$ are set based on conservative assumptions about the chemistry in the tanks, which means that deviations outside of the tolerance window will probably not lead to a corrosion rate greater than 1 mil per year. Future sampling of the waste will catch any deviations outside of the corrosion based tolerance window for $[\text{OH}^-]$ and $[\text{NO}_2^-]$.

Availability of Data:

There is abundant historical data for assessing the routine transfers with respect to corrosion limits. Non-routine transfers by definition do not have a historical database.

¹⁰ This determination may not involve further sampling of the source waste; instead, the appropriate mass balance calculations could provide the basis for complying with the compatibility program.

6.1.5 Watch List Tanks Decision Rule

No high-level waste will be accepted for transfer to a tank identified as a Watch List tank without Department of Energy approval.

Transfers to a Watch List tank shall have been reviewed prior to acceptance, to assure the potential for release of high-level waste is not increased.

6.1.6 Chemical Compatibility Decision Rule

Source wastes shall be categorized according to USEPA compatibility matrix (USEPA 1994) and potential chemical compatibility hazards identified prior to acceptance into a DST. If no potential hazard is identified the transfer may be allowed. Otherwise technical justification explaining how the waste may be safely transferred and stored in light of the potential hazard will be required before allowing the transfer.

6.2 OPERATIONS DECISION RULES

The purposes of the operations decision rules are to segregate waste into broad categories (e.g., TRU, complexant) and to ensure operability of the transfer event and of future tank farm operations.

The assumption is that the operations decision rules are adequately addressed by current operating documents, and do not require a formal statistical analysis. A summary of each operations decision rule, however is provided.

The chemical and physical data needed for the operations decision rules are summarized in Table 6-1 at the end of Section 6.

6.2.1 TRU Waste Segregation Rule

If the source waste [TRU] ≥ 100 nCi/g, then transfer waste to a TRU storage tank. Otherwise, transfer to a non-TRU tank or perform a technical evaluation demonstrating that TRU segregation will not be jeopardized (DOE 1988).

Mixing TRU with non-TRU waste could increase the costs associated with final disposal.

6.2.2 Heat Generation Rate Rule

If heat generation rate of the source waste plus that of the waste in the receiving tank is \leq OSD limit for the receiving tank the transfer may be allowed. Otherwise, a different receiving tank must be chosen.

The OSD limits are as follows (WHC 1994a, and 1994c):

- 241-AN, 241-AP, 241-AW tanks - 70,000 Btu/h
- 241-SY tanks - 50,000 Btu/h
- 241-AY, 241-AZ tanks - 700,000 Btu/h.

Heat generation rates are limited to prevent localized boiling in the AN, AP, AW, and SY tanks. The ventilation systems in these tank farms was not designed to handle boiling, and internal boiling could lead to a release of contamination. The AY and AZ farm ventilation systems were designed to handle boiling. The limit for these tanks is below the maximum rate for which the vent system was designed (10×10^6 Btu/h per tank).

6.2.3 Complexant Waste Segregation Rule

If the source waste stream is designated as complexant, then transfer the waste to a complexant waste receiver tank.

The mixing of complexant waste with non-complexant waste would likely decrease the ability to reduce waste volumes in the evaporator. Not segregating complexant waste could also increase costs associated with final disposal.

6.2.4 Waste Pumpability Rule

The waste pumpability rule is based on the Reynolds number (N_{re}) for the transfer event.

If the $N_{re} = \rho Dv/\mu$ (calculated using density (ρ), pipe diameter (D), velocity (v), and viscosity (μ)) at the conditions of transfer is $\geq 20,000$, and the volume percent solids is ≤ 30 (VanderCook et al. 1976), then allow the transfer. Otherwise, a technical evaluation demonstrating that the transfer may occur without plugging should be completed.

6.2.5 Tank Waste Type

Wastes in the tank farms have already been categorized as one of the types listed with the compatibility matrix for tank wastes, Figure 6-1. Mixing of waste types shall be in accordance with the compatibility matrix, Figure 6-1, to the extent practicable.

6.2.6 High Phosphate Waste

If the $[PO_4^{-3}] > 0.1 \text{ M}$, the waste is not to be mixed with:

- waste with $[Na^+] > 8 \text{ M}$ or
- neutralized cladding removal waste (NCRW)¹¹.

Figure 6-1. COMPATIBILITY MATRIX FOR TANK WASTES

		RECEIVER WASTE TYPE							
		DN	DSSF	DC	CC	NCRW (PD)	PT	NCAW	CP
SOURCE WASTE TYPE	DN	X	X	X	X	X	X	X	X
	DSSF	X	X						
	DC			X	X*				
	CC			X*	X				
	NCRW SOLIDS (PD)	X				X	X		
	PFP SOLIDS (PT)	X				X	X		
	NCAW							X	
	CP								X

DN dilute non-complexant waste
 DSSF double-shell slurry feed
 DC dilute complexant waste
 CC concentrated complexant waste

PD PUREX neutralized cladding removal waste
 PT TRU solids fraction from PFP Plant operations
 NCAW aging waste from PUREX
 CP concentrated phosphate waste

x Indicated waste type mixing which has occurred historically without adverse effects.

* Adding CC to DC is permitted but would not ordinarily be done. The volume of combined waste which would need to be evaporated would be increased, resulting in increased evaporation costs.

¹¹ NCRW is the solids portion of the PUREX Plant neutralized cladding removal waste stream; received in tank farms as a slurry. NCRW solids are classified as TRU waste.

Table 6-1 Analytical Data Needs for Compatibility Assessment					
Parameter	Safety Rule				Operations Rule
	Criticality	Flammable Gas	Energetics	Corrosion	
Aluminum					X
Americium-241					X
Carbonate					X
Cesium-137					X
Chloride				X	
Cooling Curve					X
Exotherm/Endotherm Ratio			X		
Fluoride					X
Hydroxide				X	X
Nitrate				X	X
Nitrite				X	X
Organic Carbon					X
Organic, Separable			X		
pH				X	
Phosphate					X
Plutonium-239/240*	X				
Solids, Vol. %	X				X
Specific Gravity		X			X
Strontium-90					X
Sulfate					X
Uranium	X				
Viscosity					X
Water, wt. %					X

* Total alpha may be used for this determination. Other fissile elements may be needed as noted in Section 4.1.1 for criticality inputs.

7.0 DQO STEP 7: SAMPLING AND ANALYSIS DESIGN OPTIONS

For sampling and analysis design it is important to distinguish between routine transfers and non-routine transfers. A routine transfer, by definition, is a type of transfer which has previously occurred and for which there is historical data on the analytical and physical measurements relevant to the safety and operations decision rules.

A generic statistical design for the sampling and analysis of routine wastes has not been developed. However, given the diluteness of routine streams and the shutdown of chemical processing on site, a single representative sample, along with the historical data, is expected to prove adequate to meet the requirements of this DQO.

The basis for this initial conclusion is that preliminary analysis of data from B Plant and PUREX indicates the adequacy of the current sampling and analysis protocols for controlling decision errors with respect to criticality safety. Should subsequent assessments of data quality demonstrate otherwise, this DQO will be reviewed. Then, sampling and analytical protocols that are expected to meet the DQO will be developed for routine waste transfer decisions.

The issue of an adequate database for historical routine transfers to address statistical process control is not easily addressed with a generic DQO. One rule of thumb is that 20 independent historical analyses are adequate to estimate the variance of the historical data. However, given the current state of shutdown production and reprocessing facilities at the Hanford Site, some routine streams are transferred so infrequently that 20 independent analyses will require several years. In this case, process control assessments will be based on fewer historical analyses.

In cases where only an upper bound exists, and a waste source analytical measurement is zero (or less than detectable), fewer than 20 historical analyses are adequate to determine if the waste source is below the bounding value for a particular analyte.

Generic designs for unique, non-routine transfer decisions will be developed in an update of this DQO. Bases for accepting non-routine transfers are likely to require more than one sample because:

- Utilization of process control charts will not be viable because of the lack of historical data.
- Second, non-routine transfers are expected to include a more concentrated and variable waste stream.

It will be necessary to make a number of critical assumptions, since by definition, there is not an adequate historical database for non-routine batches of waste. Professionals familiar with a particular batch of waste may be relied upon to provide insight regarding the level of variability in the waste.

Sampling designs for both routine and non-routine transfers will be designed to meet the confidence intervals given in Table 7-1 to the extent practicable. The values in the third column, "confidence level," represent how sure one needs to be that the transfer requirement (second column) has been met. The third column values are used to compute one sided confidence intervals; except for the corrosion decision rule which is used to compute 2 sided confidence intervals.

Analytical data, along with historical data, and process control information in some cases, which allows adherence to the confidence levels in Table 7-1 are expected to provide sufficient assurance that a transfer is safe. If adherence to the confidence levels can not be achieved, more data will be required.

Table 7-1. CONFIDENCE INTERVALS		
DECISION RULE	TRANSFER REQUIREMENT	CONFIDENCE INTERVAL
Criticality	Fissile material concentration and inventory is within criticality decision rule limits	90%
Flammable Gas	Specific gravity does not exceed flammable gas decision rule limit	90%
Energetics	Exotherm/endothrm ratio < 1	90%
Corrosion	Nitrate, nitrite and hydroxide concentrations are within corrosion decision rule limits	80%

Analytes of interest with regard to the specified decision rules are presented in Table 7-2. The analytical method and sensitivity are given for each analyte based on laboratory control standards. These analytes may be incorporated into the specific sample and analysis plans as they are developed.

7.1 PRELIMINARY ASSESSMENT OF CRITICALITY DATA

Analysis of data from B Plant and PUREX indicates that the routine source material is extremely dilute with respect to ²³⁹Pu. These data indicate that the concentration is in the range of 10⁻⁴ to 10⁻⁶ g/L, which means that

measurement error on the order of 10% will not impact decisions made for these dilute waste streams.

7.2 PRELIMINARY ASSESSMENT OF FLAMMABLE GAS ACCUMULATION CRITERION

It has been proposed that specific gravity (SpG) of waste is an acceptable predictor of flammable gas accumulation. This was determined by listing the average tank specific gravities for all double-shell tanks (DSTs). It was noted that the six DSTs that are currently on the Watch List (101-SY, 103-SY, 101-AW, 103-AN, 104-AN, and 105-AN) have the largest average SpG. Of the Watch List tanks, 105-AN has the smallest SpG, 1.43. Of the non-Watch List tanks, 105-AW has the largest SpG, 1.4. Hence, the threshold SpG was chosen between 1.40 and 1.43.

For more information regarding the suitability of the SpG limit see Reynolds 1994.

An experimental study, designed specifically to address the relationship between tank specific gravity and flammable gas accumulation, may be necessary to provide more evidence that a specific gravity of 1.41 is a sufficient threshold for preventing the formation of flammable gas Watch List tanks.

7.3 LABORATORY ANALYSIS OPTIONS

A primary need filled by this DQO is the clear specification of the data needs for waste transfers, and how these physical and chemical measurements of either the source or the receiving tank influence safety and operations related decisions. Table 7-2 summarizes available methods to measure chemical and physical properties of the source or receiving tank. An indication of the performance of these methods on actual SST waste samples is given in Dodd, 1995.

7.4 DATA REQUIREMENTS

In light of the variety of transfers which are and may be made within the tank farms and to the tank farms from other sources, it may be necessary to establish specific data requirements for a particular transfer, sampling event, or sampling regime. Every analyte is not needed to make a transfer decision for each waste stream. Table 7-3 lists the uses for data and may be used to help establish data needs for specific transfer events.

For all analytical data generated in support of this DQO quality assurance and quality control will be in accordance with the following:

1. Hanford Analytical Services Quality Assurance Plan (DOE 1995)
2. 222S Laboratory Quality Assurance Plan (WHC 1995)
3. The Hanford Quality Assurance Control Manual (WHC 1995b)
4. The TWRS Characterization Program QA Program Plan (Whelan 1994).

Quality Control (QC) performance will be expressed by precision and accuracy. These may be calculated from laboratory control standards performance, matrix spikes, duplicate analyses, and blank analyses results.

Table 7-2. Methods for Physical and Chemical Measurements Used in Waste Compatibility Decisions		
Chemical / Physical Measurement	Methods Performance Information	
	Method(s)	Sensitivity ^a
Al ⁺³	ICP	24 µg/mL
	AA	no data
²⁴¹ Am	α, AEA	10 ⁻⁵ µCi/sample
CO ₃ ⁻²	TOC/TIC	5 µg per sample
¹³⁷ Cs	γ count	10 ⁻⁵ µCi/sample
Cl ⁻	IC	0.04 µg/mL
	Spec.	no data
Cooling Curve		
Exotherm/Endotherm Ratio ^b	DSC	
	TGA	
F ⁻	IC	0.09 µg/mL
	SIE	no data
OH ⁻	Titration	0.005 M simple matrix 0.05 M complex matrix
NO ₃ ⁻	IC	0.24 µg/mL
NO ₂ ⁻	IC	0.24 µg/mL
	Spec.	0.5 µg/mL
Organic Carbon (TOC)	Furnace	1 µg/mL
	Persulfate	no data
pH	electrode	N/A
PO ₄ ⁻³	IC	0.13 µg/mL
	ICP	58 µg/mL
²³⁹ Pu	α, AEA	10 ⁻⁵ µCi/sample
Specific Gravity (SpG)	Grav/Vol	N/A
⁹⁰ Sr	β count	10 ⁻⁵ µCi/sample
SO ₄ ⁻²	IC	0.13 µg/mL
Water, Wt. %	Grav	N/A
	TGA	N/A

^a These detection limits are estimates of the instrument detection limits for simple matrices.

^b Adiabatic calorimetry is not a primary data collection measurement. The method may, however, be used to obtain a better understanding of the chemical reactivity of a waste if the energetics decision rule is not met.

7.4.1 Laboratory Control Standards

A laboratory control standard (spiked blank) or instrument calibration verification standard, should be included with each analytical batch when standards are generally available and the procedure allows for such standards. The intent is to provide an estimate of the accuracy and variability of the measurement system, including sample preparation and analysis.

Process control limits for laboratory standards should be set by either of the following methods:

- 1) When historical data are available in a database of accumulated control standard performance data, the limits can be set at the average recovery ± 3 standard deviations. When such data are being accumulated, but are insufficient at the time to establish valid statistics, an administrative limit may be used temporarily.
- 2) The control limits established by the manufacturer of commercial standards may be used as the control standard criteria.

7.4.2 Precision and Accuracy

Data precision may be measured by:

- 1) using concentration values from all samples from a source when the source is known to be homogeneous,
- 2) using duplicates or matrix spike duplicate analysis results.

Analytical accuracy can be determined from the analysis of control standards or spike recovery.

Relative percent difference (RPD) is used to quantify the precision of concentration values. RPD is defined as:

$$RPD = \frac{\text{Sample 1 Response} - \text{Sample 2 Response}}{\text{Average Sample Response}} \times 100$$

The accuracy of a sample result can be estimated by subtracting the spike percent recovery from 100 percent.

$$\% \text{ recovery} = \frac{(\text{Sample with Spike}) - \text{Sample}}{\text{Spike}} \times 100$$

Table 7-2 Determination of Analytes Requirements for Compatibility	
Parameter	Analyte Is Required:
Aluminum	For source waste when PREDICT is needed to determine complexant status
Americium-241	For source waste when needed to determine TRU status
Carbonate	For source waste when PREDICT is needed to determine complexant status
Cesium-137	For source when used to determine heat generation rate
Chloride	For source waste when receipt is through the 204-AR Facility
Cooling Curve	For source waste when needed to determine pumpability
Exotherm/Endotherm Ratio	For source when receiving wastes from outside of the DST System <u>AND</u> For source when transferring complexant waste
Fluoride	For source waste when PREDICT is needed to determine complexant status
Hydroxide	For source waste received from outside of the DST System <u>AND</u> For source waste when PREDICT is needed to determine complexant status
Nitrate	For source waste received from outside of the DST System <u>AND</u> For source waste when PREDICT is needed to determine complexant status
Nitrite	For source waste received from outside of the DST System <u>AND</u> For source waste when PREDICT is needed to determine complexant status
Organic Carbon	For source waste when PREDICT is needed to determine complexant status
Organic, Separable	For source waste received from outside of the DST System
pH	For source waste when received from outside of DST System
Phosphate	For source waste when PREDICT is needed to determine complexant status
Plutonium-239/240 ^a	For source when wastes when used to determine fissile content

Table 7-2 Determination of Analytes Requirements for Compatibility	
Parameter	Analyte Is Required:
Solids, Vol.%	For source when receiver tank contains >10 Kg Pu and either i) source contains >15 g Pu, or ii) source Pu concentration ≥ 0.013 g/L <u>AND</u> For receiver containing >10 Kg Pu when needed to show solids/Pu ≥ 1000 <u>AND</u> For source when needed to determine pumpability
Specific Gravity	For source waste for flammable gas rule determination For source waste when needed to determine pumpability
Strontium-90	For source when used to determine heat generation rate
Sulfate	For source waste when PREDICT is needed to determine complexant status
Uranium	For criticality rule determination (when needed to determine fissile content)
Viscosity	For source when N_{pe} is needed to determine pumpability

^aOther fissile elements may need to be determined as noted in Section 4.1 for criticality inputs.

8.0 REFERENCES

- Allison, J. M., 1984, "Computer Prediction of Evaporator Operation," SD-WM-ADP-004, Rev. 0, Rockwell Hanford Operations, Richland, Washington.
- Babad, H., S. M. Blacker, K. S. Redus, J. G. Hill, and J. L. Scott, 1994, *TWRS Data Quality Objectives Strategy*, WHC-EP-0732, Westinghouse Hanford Company, Richland, Washington.
- Babad, H., and D. A. Turner, 1993, *Interim Criteria for Organic Watch List Tanks at the Hanford Site*, WHC-EP-0681, Westinghouse Hanford Company, Richland, Washington.
- Delegard, C. H., and B. E. Hay to R. M. Orme, *Literature Review*, Internal Memo #12110-PCL93-056, dated June 18, 1993.
- Dodd, D. A., 1995, *Estimates of Laboratory Accuracy and Precision on Hanford Waste tank Samples*, WHC-SD-WM-ANAL-043, Rev. 0, Westinghouse Hanford Company, Richland, Washington.
- DOE, 1995, *Hanford Analytical Services Quality Assurance Plan*, DOE/RL-94-55, Rev. 1, U. S. Department of Energy, Washington, D.C.
- DOE, 1988, *Radioactive Waste Management*, DOE Order 5820.2A, U. S. Department of Energy, Washington, D.C.
- Fowler, K. D., 1995, *Tank Farms Waste Transfer Compatibility Program*, WHC-SD-WM-OCD-015, Rev. 1, Westinghouse Hanford Company, Richland, Washington.
- Mulkey, C. H., and J. M. Jones, 1994, *Double-Shell Tank Waste Analysis Plan*, WHC-SD-EV-053 Rev. 2, Westinghouse Hanford Company, Richland, Washington.
- Postma, A. K., J. E. Meacham, G. S. Barney, G. L. Borsheim, R. J. Cash, M. D. Crippen, D. E. Dickinson, J. M. Grigsby, D. W. Jeppson, M. Kummerer, J. M. McLaren, C. S. Simmons, B. C. Simpson, 1994, *Ferrocyanide Safety Program: Safety Criteria for Ferrocyanide Watch List Tanks*, WHC-EP-0691, Westinghouse Hanford Company, Richland, Washington.
- Reynolds, D. A., to N. W. Kirch, *Evaluation of Specific Gravity Versus Gas Retention*, Internal Memo #7E310-94-024, dated June 20, 1994.
- USEPA, 1994, *Waste Analysis at Facilities that Generate, Treat, Store, and Dispose of Hazardous Wastes: A Guidance Manual*, PB94-963603, OSWER 9938.4-03, April 1994

WHC-SD-WM-DQO-001, Rev. 1

- USEPA, 1993, *Guidance for Planning Data Collection in Support of Environmental Decision Making Using the Data Quality Objectives Process*, EPA QA/G4, Interim Final Guidance, USEPA.
- Vail, T. S., 1994, *Waste Storage in Double-Shell Tanks and Associated Equipment*, CPS-T-149-00010, Westinghouse Hanford Company, Richland, Washington.
- VanderCook, R. E., and W. E. Ogren, 1976, *Vacuum Evaporator-Crystallizer Flowsheet for Waste Liquors*, ARD-F-101, Atlantic Richfield Hanford Company, Richland, Washington.
- WHC, 1995, *222S Laboratory Quality Assurance Plan*, WHC-SD-CP-QAPP-016, Rev. 0, Westinghouse Hanford Company, Richland, Washington.
- WHC, 1995b, *Quality Assurance Manual*, WHC-CM-4-2, Release 77, Westinghouse Hanford Company, Richland, Washington.
- WHC, 1994a, *Unclassified Operating Specifications for the 241-AN, AP, AW, AY, AZ, & SY Tank Farms*, OSD-T-151-00007, Rev. H-8, Westinghouse Hanford Company, Richland, Washington.
- WHC, 1994b, *Unclassified Operating Specifications for the Saltwell Receiver Vessels*, OSD-T-151-00011, Rev. C-3, Westinghouse Hanford Company, Richland, Washington.
- WHC, 1994c, *Operating Specifications for Aging-Waste Operations in 241-AY and 241-AZ*, OSD-T-151-00017, Rev D-2, Westinghouse Hanford Company, Richland, Washington.
- WHC, 1994d, *Nuclear Criticality Safety Manual*, WHC-CM-4-29, Release 6, Westinghouse Hanford Company, Richland Washington.
- WHC, 1994e, *Operating Specifications for the 204-AR Waste Unloading Facility*, OSD-T-151-00008, Rev. E-2, Westinghouse Hanford Company, Richland, Washington.
- Whelan, T. E., 1994, *TWRS Characterization Program Quality Assurance Program Plan*, WHC-SD-WM-QAPP-025, Rev. 0, Westinghouse Hanford Company, Richland, Washington.