

Jessie H. Roberson, Vice Chairman

Sean Sullivan

Daniel J. Santos

**DEFENSE NUCLEAR FACILITIES  
SAFETY BOARD**

Washington, DC 20004-2901



February 2, 2015

Mr. Mark Whitney  
Acting Assistant Secretary for  
Environmental Management  
U.S. Department of Energy  
1000 Independence Avenue, SW  
Washington, DC 20585-0113

Dear Mr. Whitney:

The Safety Design Strategy (SDS) for the High-Level Waste Facility at the Hanford Waste Treatment and Immobilization Plant does not ensure the confinement ventilation system known as "C5V" will be able to effectively perform its safety class credited safety functions following a seismic design basis accident. The SDS proposes downgrading the seismic classification of several key components. This downgrade can result in penetrations through the C5V confinement boundary that compromise safety functions protecting (1) the workers by maintaining cascade airflow from areas of lower to higher contamination, and (2) the public by filtering releases prior to discharge to the environment. As a result, the preferred nuclear safety control strategy described in the SDS does not meet Department of Energy (DOE) requirements. Further details on these issues are provided in the enclosed report.

Therefore, pursuant to 42 U.S.C. § 2286b(d), the Defense Nuclear Facilities Safety Board requests a written report within 90 days of the issuance of this letter documenting DOE's plan to develop a nuclear safety control strategy such that the C5V system will be able to perform its intended safety functions effectively under the effects of a seismic design basis accident.

Sincerely,

  
Jessie H. Roberson  
Vice Chairman

Enclosure

c: Dr. Monica Regalbuto  
Mr. Joe Olencz

# DEFENSE NUCLEAR FACILITIES SAFETY BOARD

## Staff Issue Report

November 13, 2014

**MEMORANDUM FOR:** S. A. Stokes, Technical Director

**COPIES:** Board Members

**FROM:** S. Seprish, B. Boser, R. Kazban

**SUBJECT:** Seismic Control Strategy Deficiencies in the Safety Design Strategy for the High-Level Waste Facility

**Introduction.** Members of the Defense Nuclear Facilities Safety Board's (Board) staff conducted a review of the Safety Design Strategy (SDS) for the High-Level Waste (HLW) Facility [1] at the Waste Treatment and Immobilization Plant (WTP). Members of the Board's staff met with the Department of Energy (DOE) review team on April 22, 2014, to communicate preliminary concerns about the SDS. On July 16, 2014, the Board's staff members held a follow-up discussion with personnel from DOE and Bechtel National, Incorporated (BNI) to discuss outstanding concerns about the SDS. The staff members conducted an outbrief of the review conclusions with DOE and BNI personnel on September 9, 2014. One conclusion discussed during the outbrief was that several structures, systems, and components (SSC) are not seismically qualified to prevent a release through the confinement boundary of the ventilation system known as "C5V" following a seismic design basis accident (DBA). These potential unfiltered release pathways can compromise the C5V system's safety functions of maintaining cascade airflow from lower to higher contamination areas and filtering airborne releases of radioactive material. These safety class functions are credited for the seismic DBA. As a result, members of the Board's staff believe the SDS nuclear safety control strategy for a seismic DBA does not meet DOE requirements. This report compares the HLW Facility Preliminary Documented Safety Analysis (PDSA) [2] and SDS safety control strategies, and identifies how implementation of the SDS safety control strategies could result in unfiltered release pathways through the confinement boundary of the C5V system following a seismic DBA.

**Background.** In 2012, DOE restricted engineering, procurement, and construction work for the HLW Facility due to unresolved technical and programmatic issues, as well as misalignments of the design and safety basis. In October 2013, the DOE Office of River Protection (ORP) identified activities that BNI must perform to support a conditional authorization to proceed with engineering, procurement, and construction work. One of the prerequisites for DOE-ORP to grant the conditional authorization to proceed with engineering, procurement, and construction was for BNI to develop and submit an SDS for the HLW Facility. On August 1, 2014, the DOE-ORP manager and the WTP Federal Project Director approved the SDS with concurrence from the DOE Chief of Nuclear Safety and the Associate Deputy Assistant Secretary for Safety, Security, and Quality Programs for Environmental Management.

The SDS states that it "... provides the basis for updating, and ultimately revising, the [PDSA] for the [HLW] Facility to ensure the final design is compliant with 10 CFR [Code of Federal Regulations] 830, Part B, *Nuclear Safety Management*. This SDS is a re-alignment to guide future hazard analyses, design activities, and technical issue resolutions, culminating in a revised PDSA to be submitted for approval." An SDS is a concept from DOE Standard 1189, *Integration of Safety into the Design Process*, and is typically developed early in the project life to guide design and safety basis development. However, this SDS is a unique, tailored application of the concept to a partially constructed facility with several outstanding technical issues and a previously approved PDSA. Additionally, DOE Standard 1189 is not included in the WTP code of record. The HLW Facility SDS contains the preferred nuclear safety controls for the facility. The content and nuclear safety control strategy outlined in the SDS will have direct implications on the safety basis. Therefore, a deficient SDS may lead to incomplete reconstitution of the PDSA and to a safety basis that does not meet the requirements of 10 CFR 830. DOE Order 420.1B, *Facility Safety* [3], is included in the WTP code of record and, per 10 CFR 830, defines nuclear safety design criteria for use in PDSAs.

**Comparison of Safety Control Strategies.** The PDSA and SDS safety control strategies for a seismic DBA intend for releases to be filtered prior to exiting the boundary of the C5V system. The C5V system is designed to remain intact and functional following a seismic DBA. The classification associated with this design requirement is seismic category (SC)-I. In contrast, SC-III SSCs are not designed to withstand a seismic DBA, but are designed to withstand less severe seismic events. The PDSA safety control strategy includes the barriers and controls listed in Table 1 to prevent unfiltered releases from the confinement boundary of the C5V system following a seismic DBA. Table 1 also shows how the SDS makes modifications to the safety control strategy for a seismic DBA outlined in the PDSA.

**Table 1:** A Comparison of PDSA and SDS Safety Control Strategies for a Seismic DBA.

<b>SSC</b>	<b>PDSA</b>	<b>SDS</b>
C5V	The C5V system is safety class and SC-I to: (1) mitigate release consequences by providing active confinement to maintain control of contamination, and (2) mitigate consequences of an airborne release of radioactive material by filtering the exhaust prior to discharge to the environment.	The C5V system is safety class and SC-I to: (1) mitigate consequences by providing active ventilation and confinement to maintain control of contamination through cascading air flow from lower contamination to higher contamination areas, and (2) mitigate consequences of an airborne release of radioactive material by filtering the exhaust prior to discharge to the environment.
Submerged Bed Scrubbers	The submerged bed scrubbers are safety class and SC-I to mitigate the consequences of the release of radioactive offgas by maintaining a liquid seal that confines radioactive offgas to the ventilated area of the C5V system. This liquid seal prevents offgas from flowing to areas outside the C5V system confinement boundary.	The submerged bed scrubbers are safety significant and SC-III. Therefore, during a seismic DBA, the submerged bed scrubbers may fail and be unable to provide a liquid seal for radioactive offgas.
HOP system HEPA Filters	The HLW Melter Offgas Treatment Process (HOP) system high efficiency particulate air (HEPA) filters are safety class and SC-I to mitigate the consequences of the release of radioactive offgas by providing confinement and filtration of the melter offgas.	The HOP system HEPA filters are safety significant and SC-III. Therefore, during a seismic DBA, the HOP HEPA filters may fail and be unable to provide radioactive offgas confinement and filtration.
Hydrogen Mitigation	The air amplifiers on the HLW Melter Feed Process (HFP) system vessels are safety class and SC-I to draw a vacuum on the headspaces of the HFP system vessels and direct airflow out of the vessels. The airflow from the air amplifiers is filtered by the SC-I C5V HEPA filters.	A safety class and SC-I air purge replaces the air amplifiers. The air purge pressurizes the HFP vessel headspaces rather than maintaining them at negative pressure.
Melter Pressure Relief Device	The melter overpressure relief devices are safety significant and SC-III to mitigate the consequences of melter overpressure by relieving the offgas to the C5V area.	The melter pressure relief devices are safety significant and SC-III to mitigate the consequences of an offgas release by relieving offgas via a controlled pathway to a C5 area upon positive plenum pressure.

**Safety Concerns.** SC-III SSCs may fail following a seismic DBA. A robust safety control strategy for a seismic DBA would consider possible failure states of SC-III SSCs. For example, DOE Guide 420.1-2, *Guide for the Mitigation of Natural Phenomena Hazards for DOE Nuclear Facilities and Nonnuclear Facilities* [4], states: “The design and evaluation process should consider potential damage and failure of SSCs due to both direct natural phenomena effects, including common cause, and indirect natural phenomena effects, including interaction with other SSCs.” Implementing the SDS safety control strategy for a seismic DBA could result in several potential unfiltered flowpaths to the public and the workers. These flowpaths are explained below:

- The SDS proposes downgrading the submerged bed scrubber and the HOP system HEPA filters to safety significant and SC-III. As a result, a potential unfiltered release pathway for radioactive offgas exists to occupied spaces outside the confinement boundary of the C5V system and possibly to the environment. Figure 1 illustrates this potential flowpath.
- Following a seismic DBA, the HFP system vessels will be above atmospheric pressure. Because the SDS proposes downgrading the HOP system HEPA filters to safety significant and SC-III, a potential unfiltered release pathway exists to occupied spaces outside the confinement boundary of the C5V system and possibly to the environment. Figure 2 illustrates this potential flowpath.

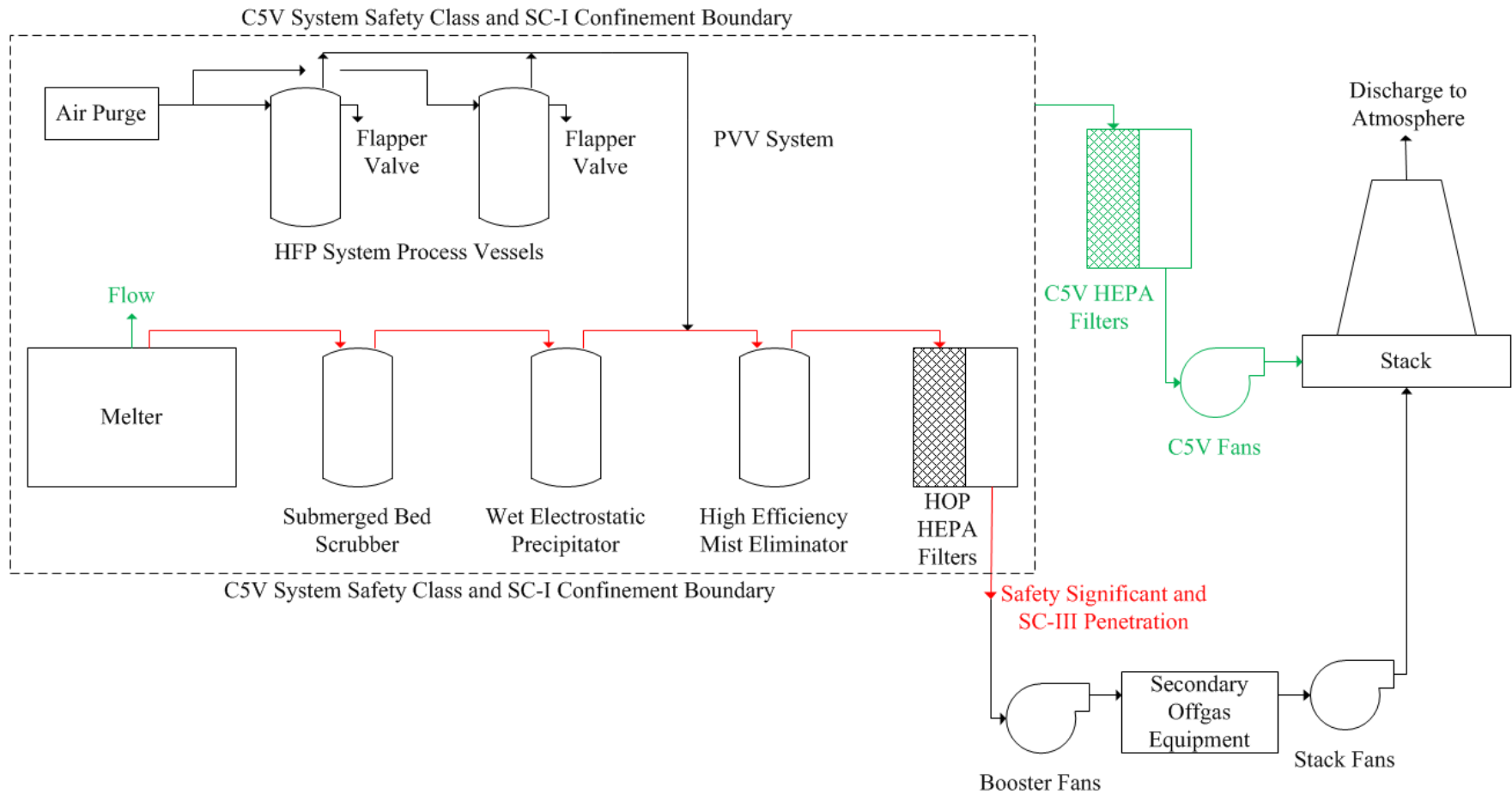

**Figure 1:** A simplified illustration of the HFP, Process Vessel Vent Exhaust (PVV), HOP and C5V systems. The safety class and SC-I C5V system confinement boundary is shown by the dashed line. Following a seismic DBA, the credited flowpath for melter offgas is from the melter through the C5V system HEPA filters (shown in green). The preferred control strategy in the SDS proposes to downgrade the safety and seismic classification of the submerged bed scrubber and HOP system HEPA filters to safety significant and SC-III, establishing a potential unfiltered SC-III flowpath through the SC-I confinement boundary (shown in red).

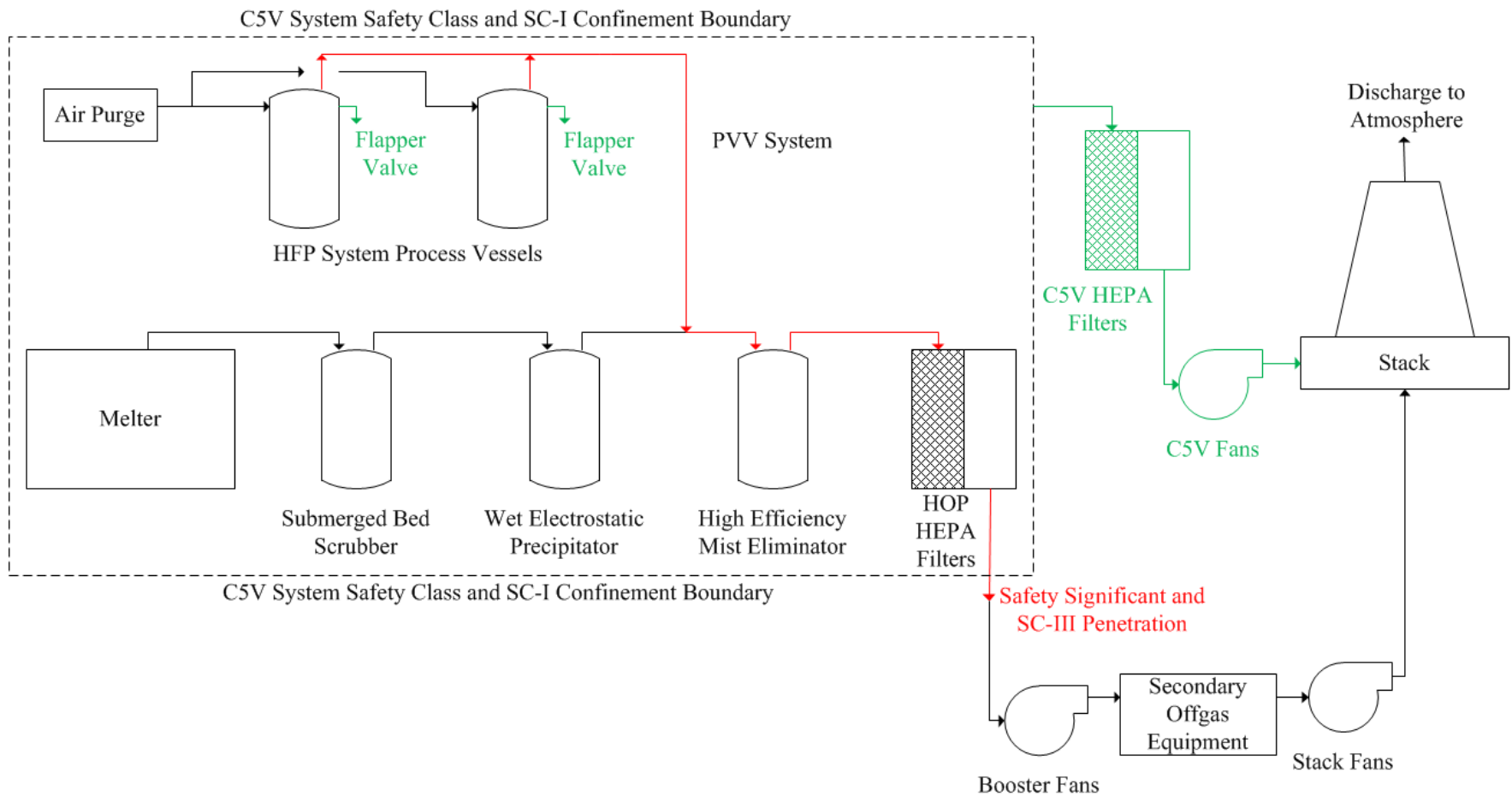

**Figure 2:** A simplified illustration of the HFP, PVV, HOP and C5V systems. The safety class and SC-I C5V system confinement boundary is shown by the dashed line. Following a seismic DBA, the credited flowpath for the air purge is from the HFP system process vessels through the C5V system HEPA filters (shown in green). The preferred control strategy in the SDS proposes to downgrade the safety and seismic classification of the HOP system HEPA filters to safety significant and SC-III, establishing a potential unfiltered SC-III flowpath through the SC-I confinement boundary (shown in red).

**DOE Requirements.** Following a seismic DBA, the SDS credits the SC-I C5V system with the safety class functions of maintaining cascade airflow from areas of lower to higher contamination and for filtering exhaust prior to discharge to the environment. The SDS proposes downgrading the safety classification and seismic category of the HOP system HEPA filters and submerged bed scrubber. The downgrade in safety classification and seismic category may allow unfiltered flowpaths through the confinement boundary of the C5V system and prevent it from performing its credited safety functions effectively under the effects of a seismic DBA. This is not consistent with the following DOE requirements:

- DOE Order 420.1B states: “DOE facilities and operations must be analyzed to ensure that SSCs and personnel will be able to perform their intended safety functions effectively under the effects of NPH [natural phenomenon hazards]” and “Facility SSCs must be designed, constructed, and operated to withstand NPH and ensure—(a) confinement of hazardous materials; (b) protection of occupants of the facility, as well as members of the public....”
- DOE Standard 1020-94 (Change 1, 1996), *Natural Phenomena Hazards Design and Evaluation Criteria for Department of Energy Facilities* [5], discusses when Performance Category (PC)-3<sup>1</sup> SSCs are appropriate: “Design considerations for these categories are to limit SSC damage so that hazardous materials can be controlled and confined, occupants are protected, and functioning of the SSC is not interrupted.”
- DOE Standard 3009-94, *Preparation Guide for U.S. Department of Energy Nonreactor Nuclear Facility Documented Safety Analyses* [6], states: “Identify SSCs whose failure would result in a safety-class SSC losing the ability to perform its required safety function. These SSCs would also be considered safety-class SSCs for the specific accident conditions for which the safety-class designation was made originally.”

**Conclusion.** Alternative engineered controls may be available that could be added to the design to offset downgrading the submerged bed scrubber and HOP HEPA filters to safety significant and SC-III. The engineered controls would be designed to prevent the unfiltered releases through the confinement boundary of the C5V system following a seismic DBA. However, with the existing design, members of the Board’s staff conclude the proposed safety and seismic downgrade to the submerged bed scrubber and HOP HEPA filters does not meet DOE requirements. The content and nuclear safety control strategy outlined in the SDS will have direct implications on the safety basis. Therefore, a deficient SDS may lead to incomplete reconstitution of the PDSA and a safety basis that does not meet the requirements of 10 CFR 830. The SDS safety control strategy for a seismic DBA would be strengthened by addressing the safety concerns in this report.

---

<sup>1</sup> SC-I SSCs meet PC-3 design criteria of DOE Standard 1020-94 (Change 1, 1996).



### **Cited References.**

1. Bechtel National Inc., *Safety Design Strategy for the High-Level Waste Facility*, 24590-HLW-PL-ENS-13-0001, Rev 0, Richland, WA, June 2014.
2. Bechtel National, Inc., *Preliminary Documented Safety Analysis to Support Construction Authorization; HLW Facility Specific Information*, 24590-WTP-PSAR-ESH-01-002-04, Rev 5d, Richland, WA, December 2014.
3. U.S. Department of Energy, *Facility Safety*, DOE Order 420.1B, Washington, D.C., December 22, 2005.
4. U.S. Department of Energy, *Guide for the Mitigation of Natural Phenomenon Hazards for DOE Nuclear Facilities and Nonnuclear Facilities*, DOE Guide 420.1-2, Washington, D.C., March 2000.
5. U.S. Department of Energy, *Natural Phenomena Hazards Design and Evaluation Criteria for Department of Energy Facilities*, DOE Standard 1020-94 (Change 1, 1996), Washington, D.C., 1996.
6. U.S. Department of Energy, *Preparation Guide for U.S. Department of Energy Nonreactor Nuclear Facility Documented Safety Analyses*, DOE Standard 3009-94, Washington, D.C., July 1994.